

CAUTION : Read instructions thoroughly and completely prior to beginning installation.

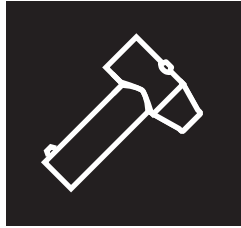











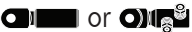

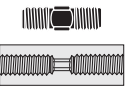
Installation instructions for multiple cable arrangement - Type C interface

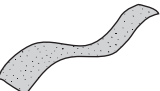

(K),(M),(P)809PB/G
Up to 42 kV

Only to be used on copper wire screened cable with extruded easy strip or bonded semi-conductive screen and stranded circular conductors of copper or aluminium.

Contents :

 3 x 809PB/G coupling connector	 3 x Cable reducer 911CA-W	 or  +  3 x Conductor contact - TBC-X or TMBC-X + Installation instructions	 3 x Contact rod and stud
 Field control mastic, type MFC-RLT	 Water sealing mastic, type MWS (outdoor applications)	 Water sealing mastic, type NGAF (outdoor applications)	 +  Silicone grease + wipers
 Roll adhesive tape	 Sand paper	 1 x Nylon vent rod	 Installation instructions
 Gloves			

For installation on a 489TB/G tee connector or a 809PB/G coupling connector tightened with a stud, washer and nut :

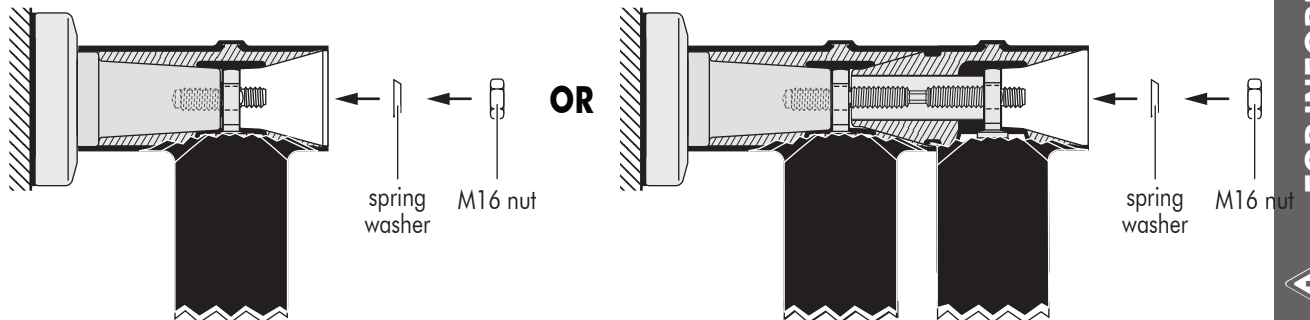

Euromold
a Nexans company

This product should be installed only by competent personnel trained in good safety practices involving high voltage electrical equipment. These instructions are not intended as a substitute for adequate training or experience in such safety practices. These instructions do not attempt to provide for every possible contingency. Failure to follow these instructions could result in damage to the product and serious or fatal injury. **IMPORTANT :** Cable and associated apparatus must be de-energised, locked out, and tagged prior to product installation.

NB : Only one phase is shown in these instructions. Make off all three phases the same way. Use a cable conversion kit for 3-core cables.

CABLE PREPARATION

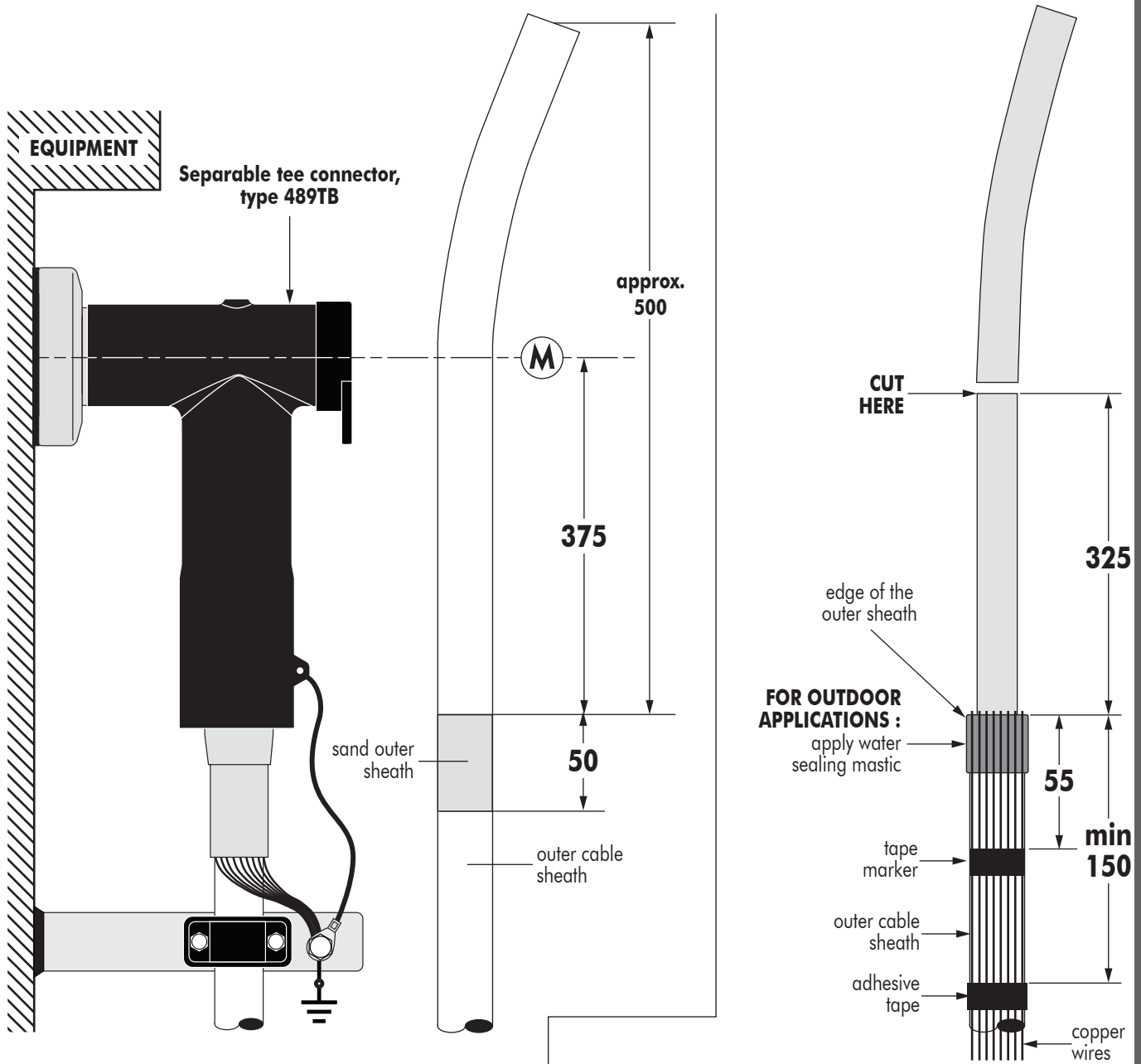

- 1 Train the cable into the approximate finished position next to the equipment bushing.
- 2 Mark the centre line « M » of the bushing.
- 3 Remove the outer cable sheath to a point **375** mm from the centre line « M » of the bushing.
- 4 Sand the outer sheath over a distance of **50** mm.
- 5 Apply a tape marker around the outer sheath **55** mm from the edge. For indoor applications, bend the screen wires back over the outer sheath and proceed to step no. 6.

For outdoor applications :

- Wrap one layer of water sealing mastic (type MWS) around the outer sheath, flush with the end (**25** mm minimum width). Completely encircle the cable.
- Bend the screen wires back over the mastic and along the outer sheath, pressing them into the mastic.

IMPORTANT : screen wires should not touch each other when pressed into the mastic to prevent water ingress.

- 6 Using adhesive tape, fix the screen wires at a distance of min **150** mm from the edge of the outer sheath.
- 7 Cut the cable to a point **325** mm from the outer sheath.

FOR INFORMATION ONLY Please always use the instructions supplied in the kit

For extruded easy strip semi-conductive screen

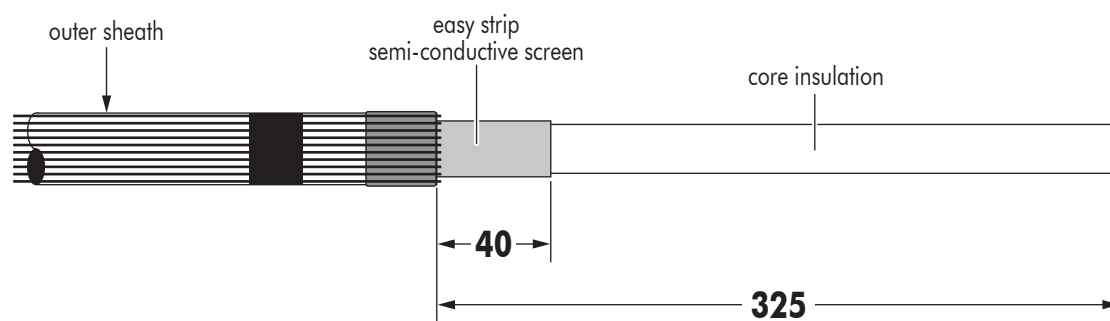

- 1 Check distance of **325** mm.
- 2 Remove the easy strip semi-conductive screen to a point **40** mm from the outer sheath. Cut squarely taking care not to cut the core insulation.

For bonded extruded semi-conductive screen

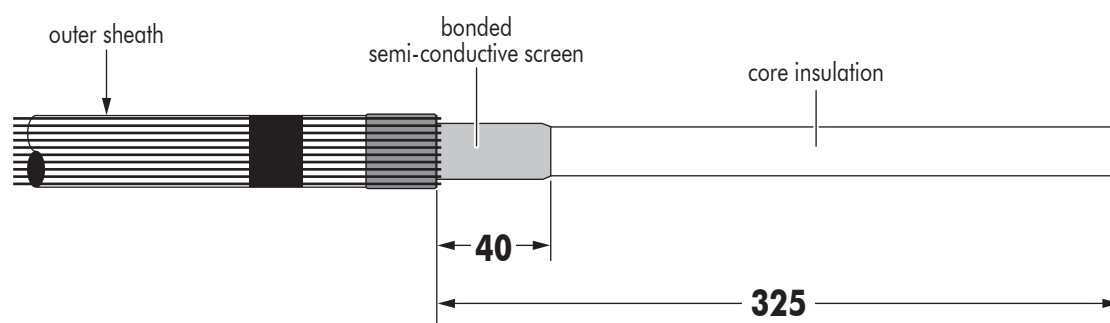

- 1 Check distance of **325** mm.
- 2 Remove the bonded semi-conductive screen to a point **40** mm from the outer sheath. Use an appropriate pencilling tool. Make a smooth transition between core insulation and semi-conductive screen.
- 3 **Remove any traces of conductive residue from the core insulation.**



REMOVAL OF THE CORE INSULATION

A. Compression type contacts (Type TBC-X)

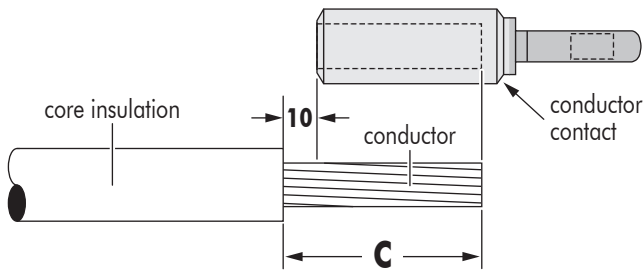

B. Mechanical type contacts (Type TMBC-X)

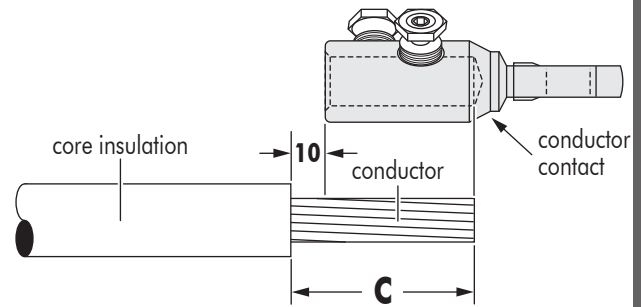

- 1 A. For compression type contacts :** remove the core insulation from the conductor for a distance « **C** » mm (**C** = depth of contact bore + 10 mm).
- 1 B. For mechanical type contacts :** remove the core insulation from the conductor for a distance « **C** » mm (**C** = depth of contact bore + 10 mm).

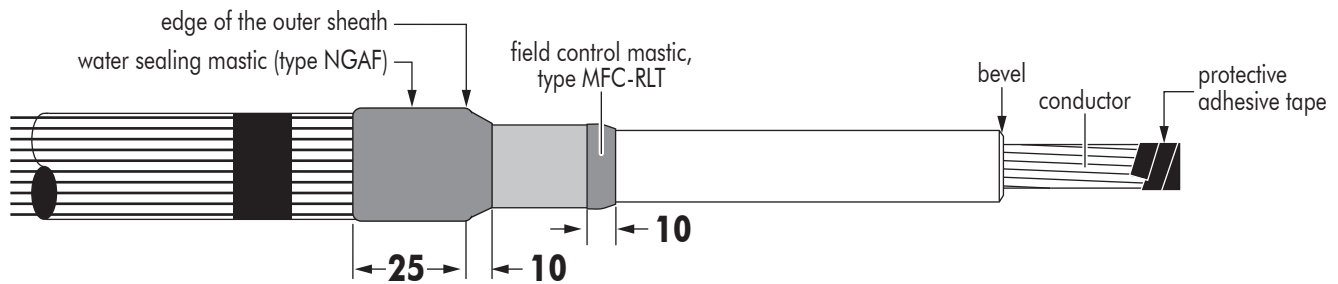

- 2** Slightly bevel the edge of the core insulation. **Do not sharpen in cone-shape.**
- 3 Thoroughly clean core insulation.** Always wipe towards the screen wires.
- 4** As a protection, wrap a few turns of adhesive tape around the conductor end.
- 5** Remove field control mastic strip, type MFC, from coated paper. Apply the mastic on the cutback edge of the semi-conductive screen, covering approximately **5** mm of the extruded semi-conductive screen and **5** mm of the core insulation. Push the mastic in place while stretching it progressively until both ends overlap and tear-off the excess mastic. Using the coated side of the paper, squeeze the mastic tightly in place on the step of the semi-conductive screen.
- 6 For outdoor applications:** Wrap another layer of water sealing mastic (type NGAF). Start taping **25** mm from the end of the outer sheath over the first mastic layer and the screen wires and continue up to a point **10** mm on the semi-conductive screen. Make a cone-shape.

INSTALLATION OF THE CABLE REDUCER

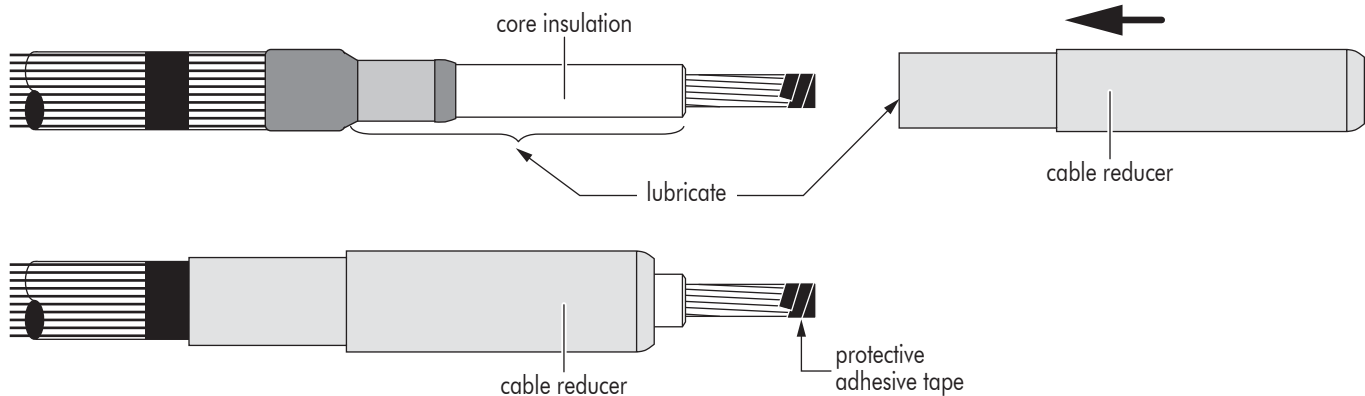

- 1** Lubricate* the indicated area : core insulation, mastic, semi-conductive screen and inner surface of the reducer.
- 2** Slide the reducer down the cable.
- 3** Remove the protective adhesive tape from the conductor.

* USE ONLY THE SILICONE LUBRICANT SUPPLIED

FOR INFORMATION ONLY Please always use the instructions supplied in the kit



CRIMPING/TIGHTENING OF THE CONTACT

A

Compression type contacts (Type TBC-X)

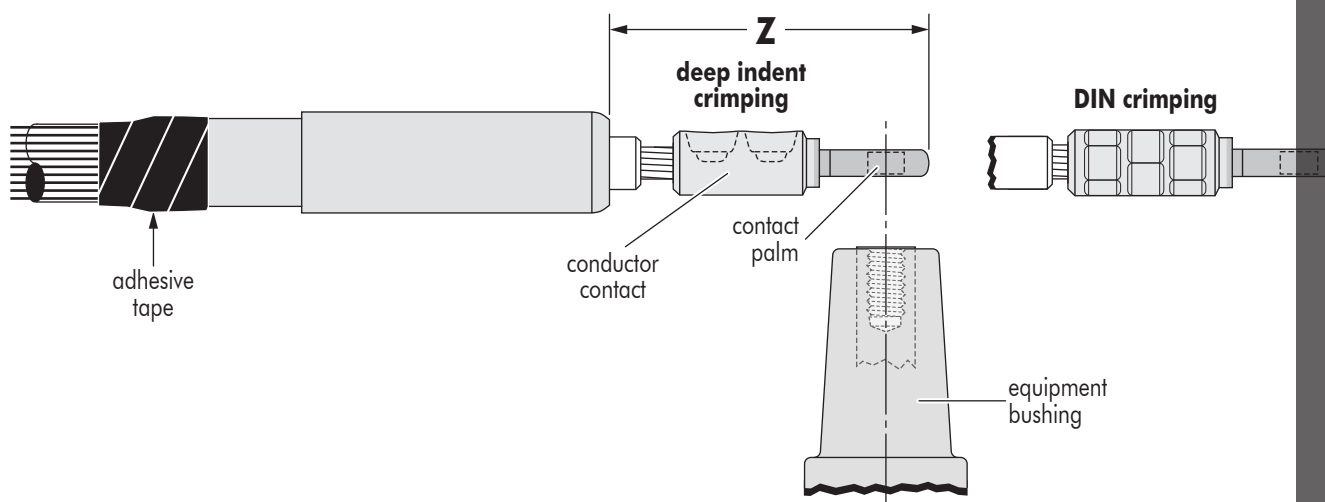

- 1 For aluminium conductors : before installing the conductor contact, wire brush the conductor.
- 2 Fit the contact on to the conductor.
- 3 Position the crimp contact taking care that the contact hole aligns with the bushing hole.
- 4 Prior to crimping, distance « **Z** » must be between **225** and **230** mm.
- 5 Crimp the contact. Please refer to the crimp chart for crimp sequence.
- 6 After crimping distance « **Z** » must be between **225** and **235** mm.
If necessary, adjust the position of the cable reducer until distance « **Z** » is within the tolerance range.
Using adhesive tape, secure the cable reducer.
- 7 **Remove any burrs left after crimping and wipe-off excess inhibitor.**



FOR INFORMATION ONLY Please always use the instructions supplied in the kit



B

Mechanical type contacts (Type TMBC-X)

Before tightening

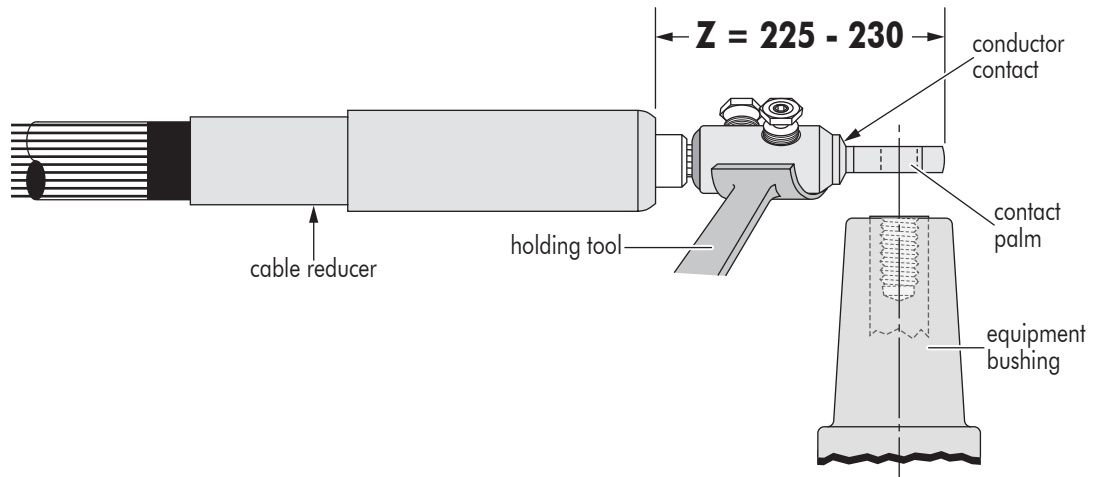

- 1 For aluminium conductors : before installing the conductor contact, wire brush the conductor.
- 2 Insert, if necessary, the centre ring into the contact barrel according to the table in the contact installation instruction.
- 3 Position the contact taking care that the contact hole aligns with the bushing hole.
- 4 Before tightening, distance « **Z** » must be between **225** and **230** mm.
- 5 Tighten the contact. Please refer to the installation instruction included with the contact.

After tightening

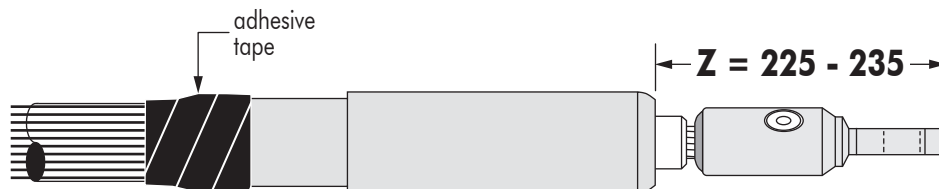

- 6 After tightening, distance « **Z** » must be between **225** and **235** mm.
If necessary, adjust the position of the cable reducer until distance « **Z** » is within the tolerance range.
Using adhesive tape, secure the cable reducer.



FOR INFORMATION ONLY Please always use the instructions supplied in the kit



COUPLING CONNECTOR INSTALLATION ON CABLE

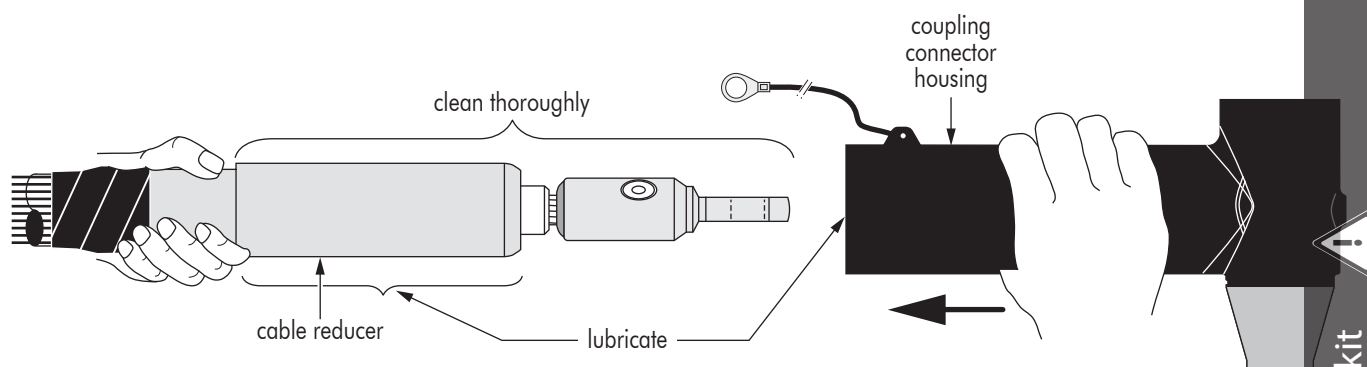

- 1 Clean cable reducer, core insulation and contact.**
- 2** Lubricate* the inside surface of the connector housing and outer surface of the cable reducer.
- 3** Check if the **outer cone interface is pointed towards the bushing**. Whilst preventing the cable reducer from further movement down the cable gently slide the housing on the cable. Its final position is reached when the centre of the contact spade is along the axis of the interfaces of the connector.
- 4 The cable reducer must stay in place during installation.**

COUPLING CONNECTOR INSTALLATION ON TEE CONNECTOR

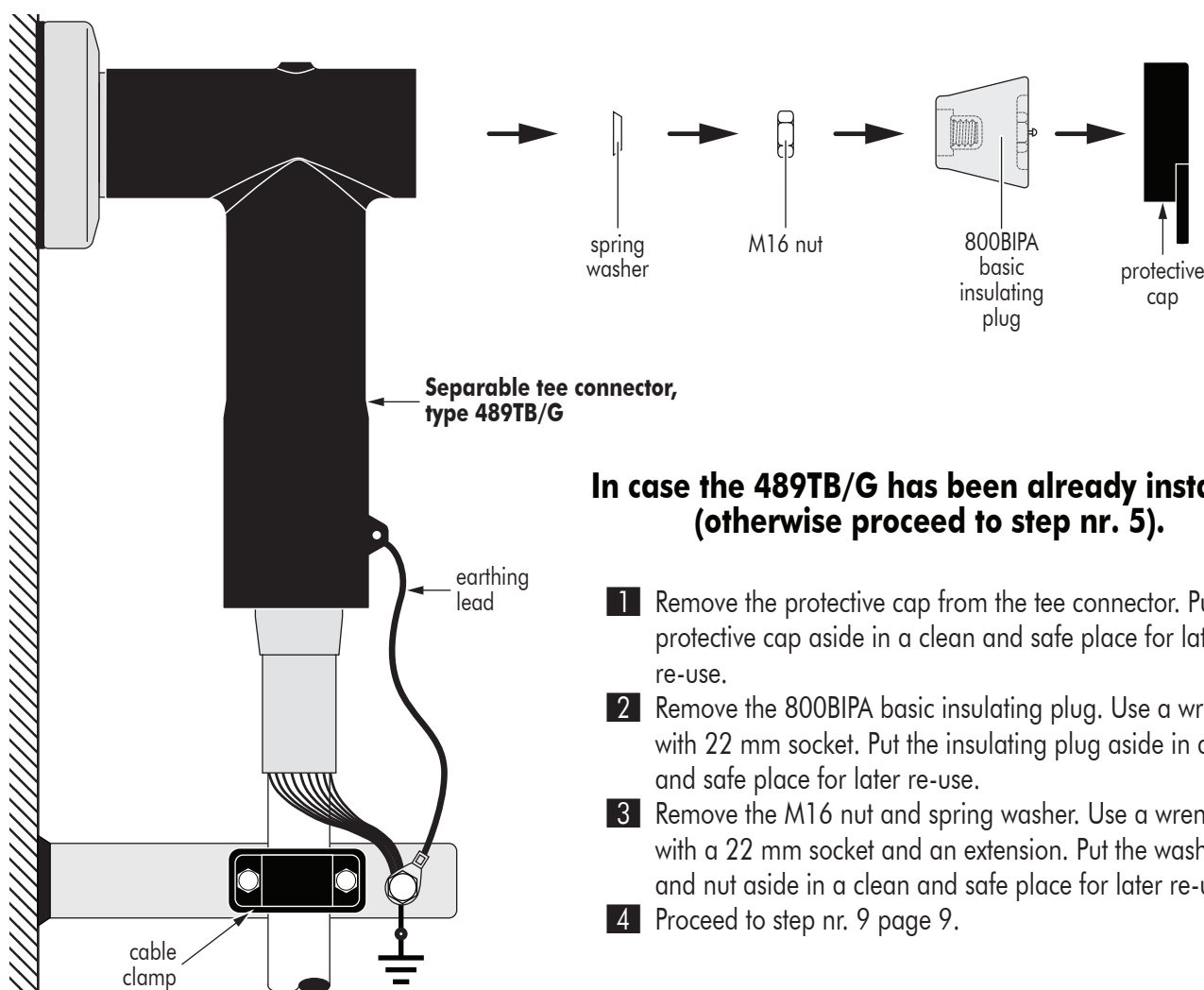

In case the 489TB/G has been already installed (otherwise proceed to step nr. 5).

- 1** Remove the protective cap from the tee connector. Put the protective cap aside in a clean and safe place for later re-use.
- 2** Remove the 800BIPA basic insulating plug. Use a wrench with 22 mm socket. Put the insulating plug aside in a clean and safe place for later re-use.
- 3** Remove the M16 nut and spring washer. Use a wrench with a 22 mm socket and an extension. Put the washer and nut aside in a clean and safe place for later re-use.
- 4** Proceed to step nr. 9 page 9.

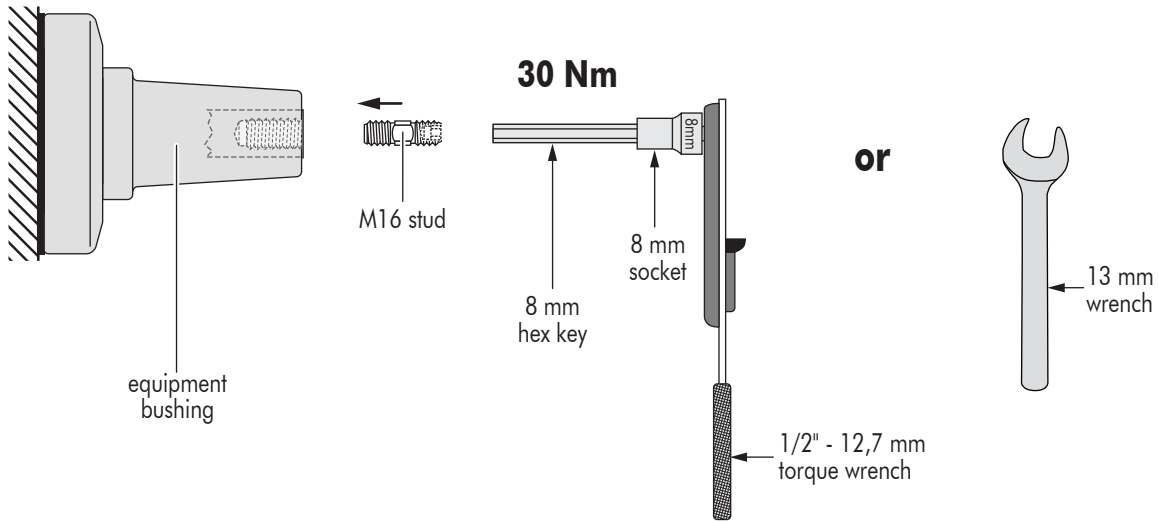

- 5 Install M16 threaded stud into the bushing interface.
- 6 Using a 13 mm wrench or a hex key of 8 mm, tighten the stud exerting **30 Nm** (3 kgm or 22,1 foot-pounds).

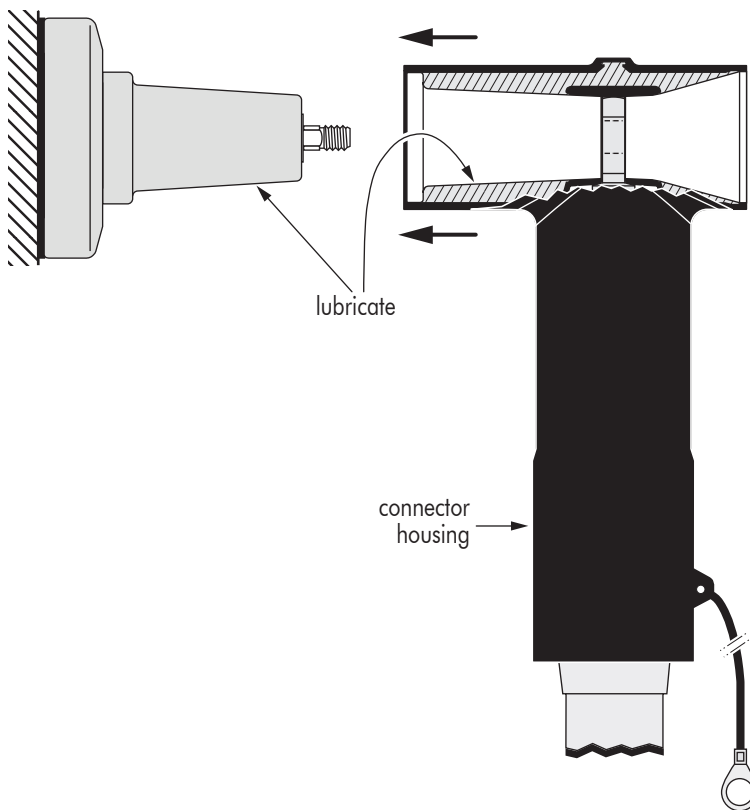

- 7 Clean and lightly lubricate* both connector and bushing interface.
- 8 Push the 489TB/G connector on to the bushing.

* USE ONLY THE SILICONE LUBRICANT SUPPLIED



FOR INFORMATION ONLY Please always use the instructions supplied in the kit



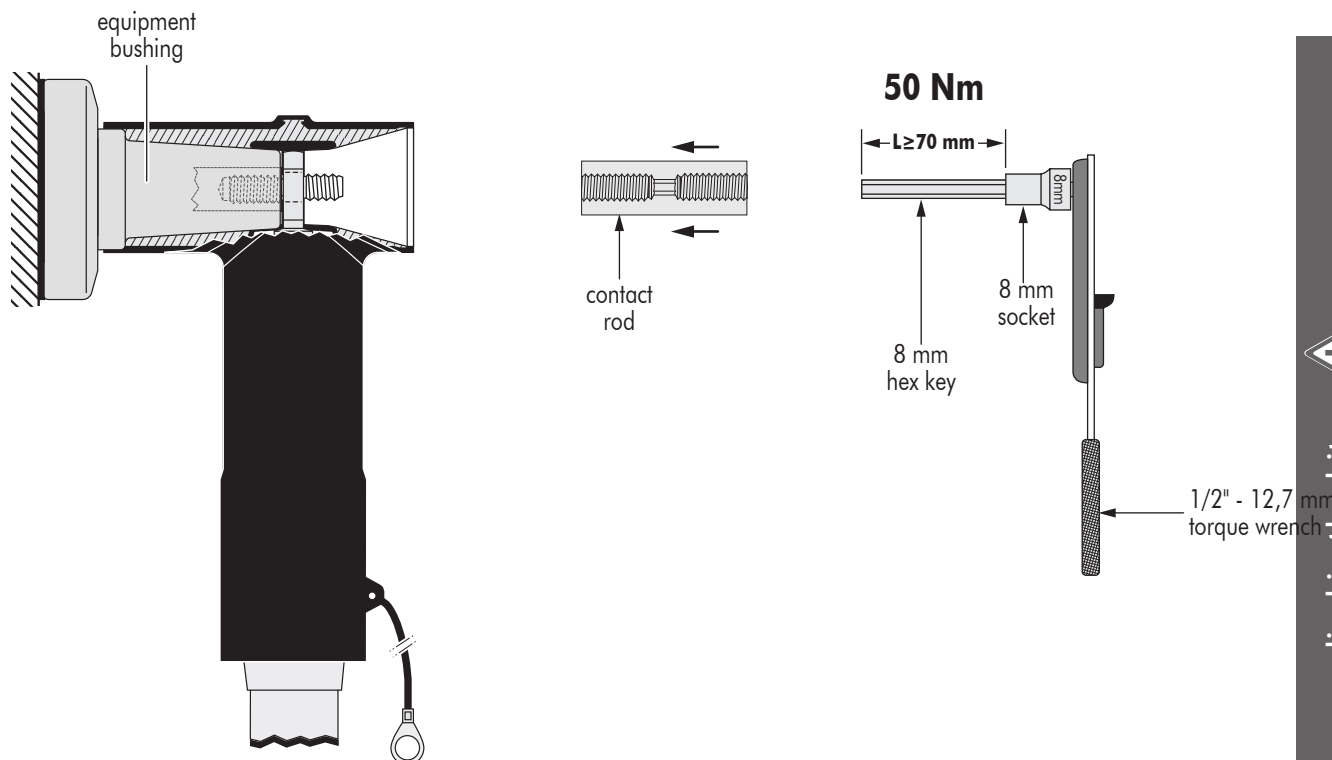

- 9 Insert the contact rod on to the threaded stud.
- 10 Use a torque wrench with a 8 mm socket and an hex key of 8 mm and tighten exerting **50 Nm** (5 kgm or 36,9 foot-pounds) of torque.

In order to achieve the correct applied torque ensure that there is no lubricant on the threaded parts.

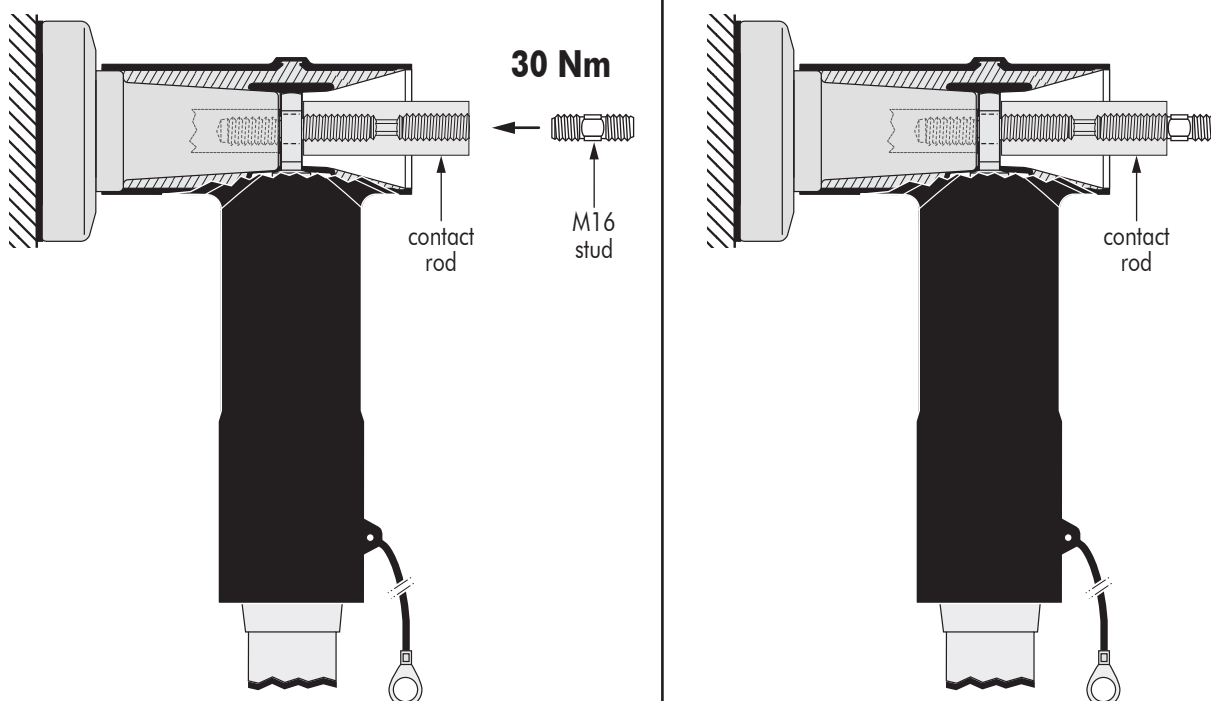

- 11 Install the M16 threaded stud into the bushing interface.
 - 12 Using a 13 mm wrench or a hex key of 8 mm, tighten the stud exerting **30 Nm** (3 kgm or 22,1 foot-pounds).
- In order to achieve the correct applied torque ensure that there is no lubricant on the threaded parts.**



FOR INFORMATION ONLY Please always use the instructions supplied in the kit



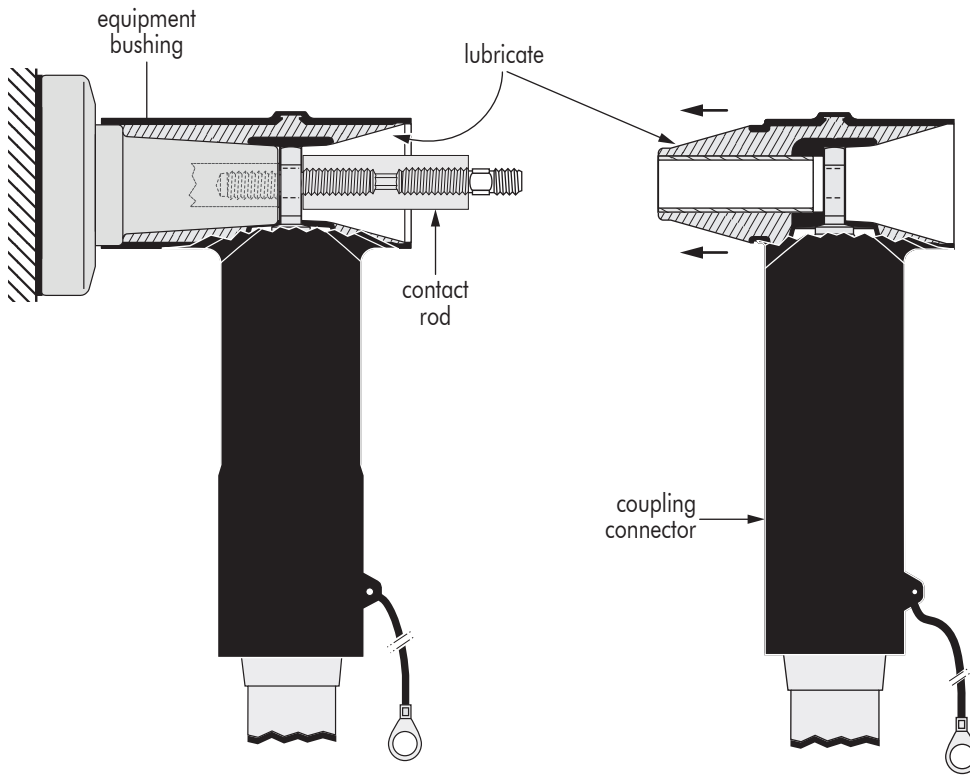

- 13 Clean and lubricate* both female tee connector interface and male interface of the coupling connector.
- 14 Push the coupling connector on to the contact rod of the tee connector. Take care not to damage the contact rod during installation of the coupling connector.

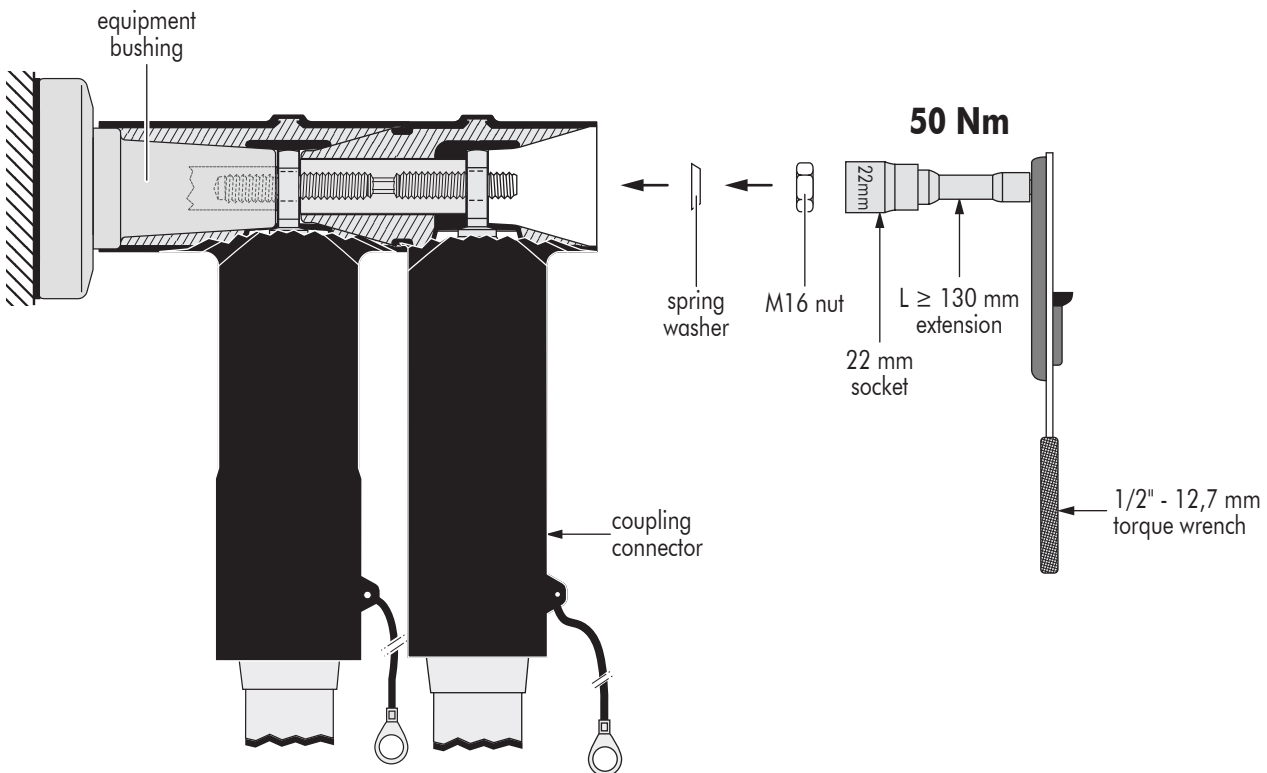

- 15 Install the spring washer and M16 nut on to the threaded stud.
- 16 Use torque wrench with extension and socket wrench 22 and tighten exerting **50 Nm** (5 kgm or 36,9 foot-pounds) of torque.
In order to achieve the correct applied torque ensure that there is no lubricant on the threaded parts.

* USE ONLY THE SILICONE LUBRICANT SUPPLIED



FOR INFORMATION ONLY Please always use the instructions supplied in the kit



INSTALLATION OF THE BASIC INSULATING PLUG

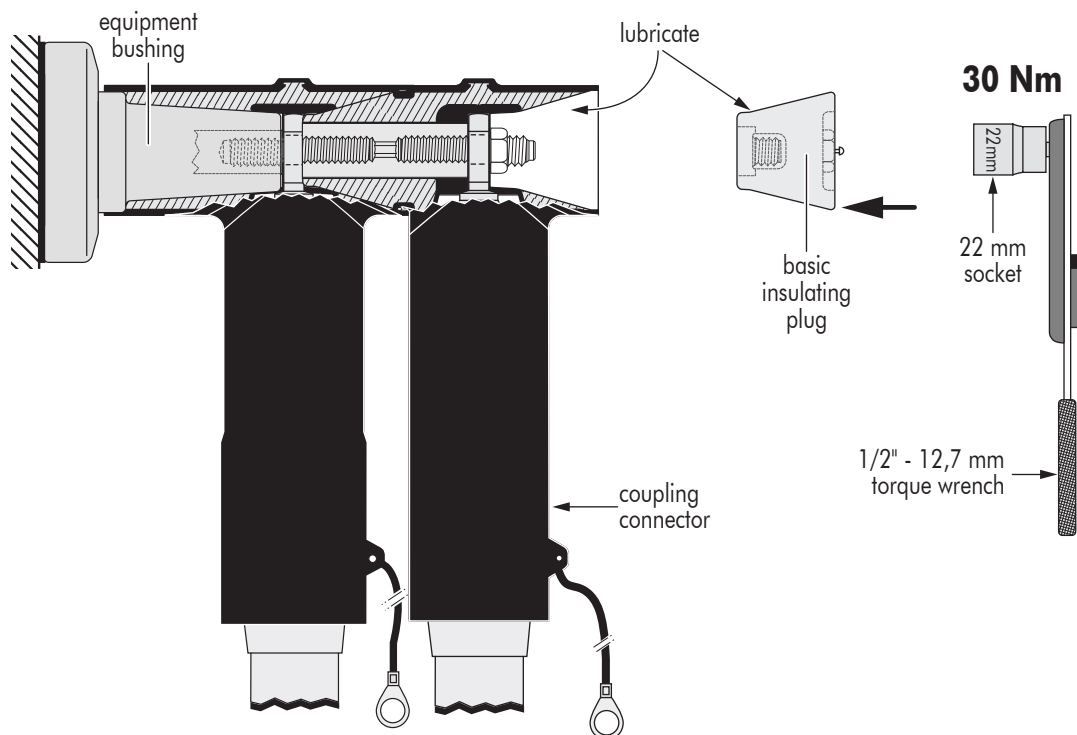

- 1 Clean and lubricate* the insulating plug and the female interface of the coupling connector.
- 2 Insert the plug into the connector and tighten assembly : use torque wrench with socket of 22 and tighten exerting **30 Nm** (5 kgm or 36,9 foot-pounds) of torque.
In order to achieve the correct applied torque ensure that there is no lubricant on the threaded parts.

INSTALLATION OF THE CAP

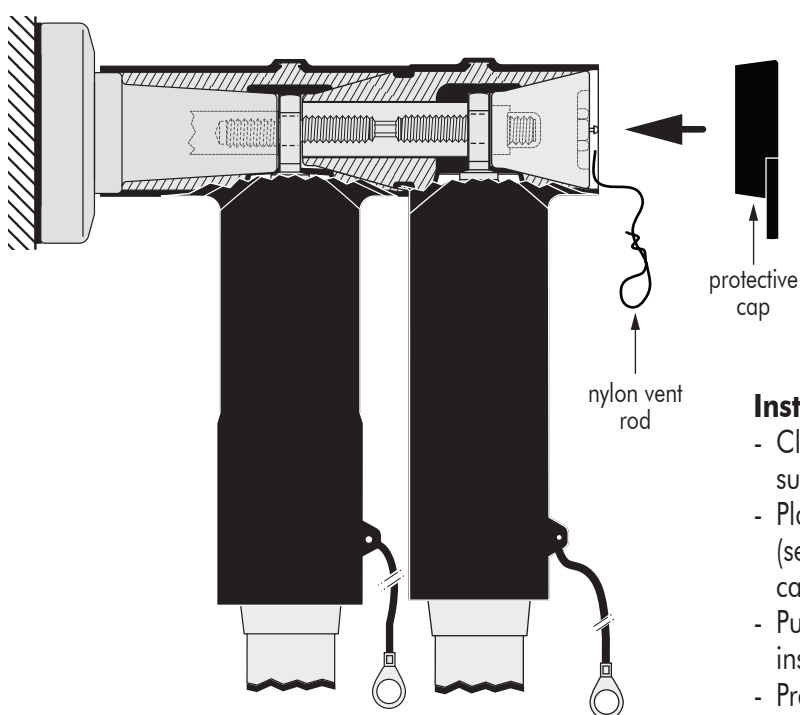

Installation on insulating plug :

- Clean the inside of the cap and the outside surface of the connector and insulating plug.
- Place the nylon vent rod along the insulating plug (see fig.) to exhaust the air during assembly of the cap.
- Push the cap over the connector and on to the insulating plug.
- Press the centre of the cap on to the locking point until it snaps in place. Press the cap on all sides to make sure it is well positioned over the connector. Position the cap with the pulling tab pointing downwards.
- Remove the nylon vent rod.



FOR INFORMATION ONLY Please always use the instructions supplied in the kit



CONNECTOR EARTHING AND CABLE CLAMPING

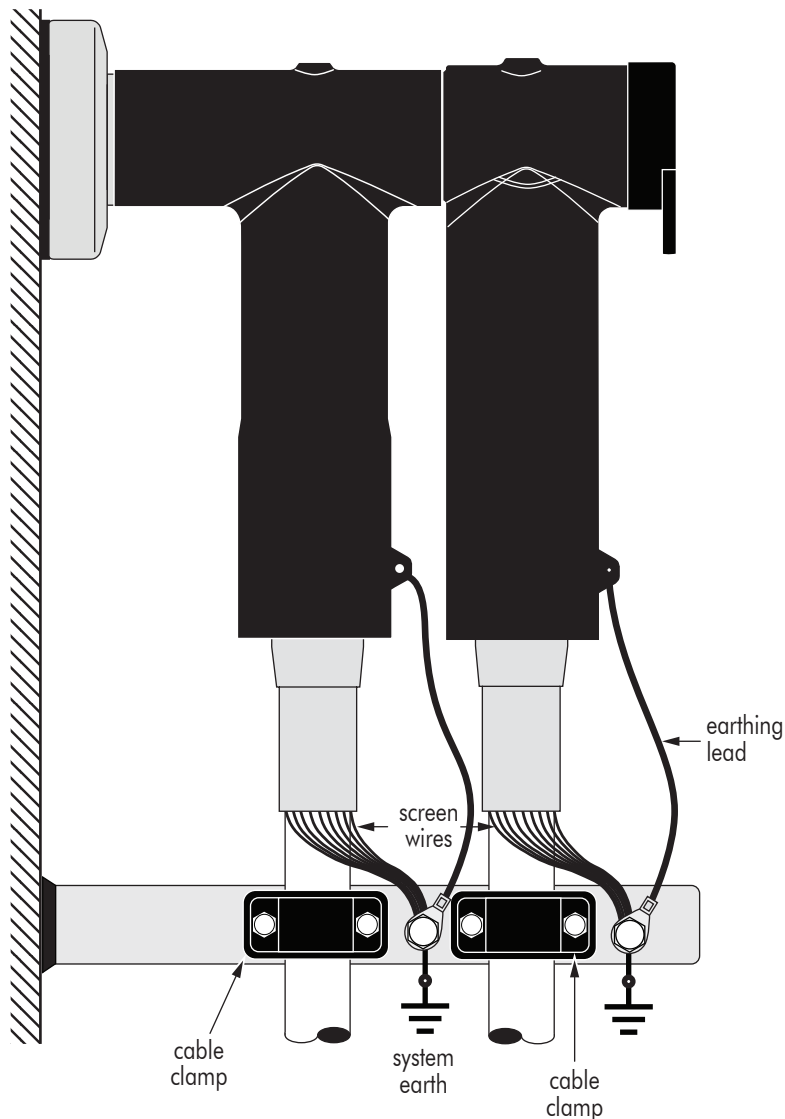

- 1 Bend back the screen wires along the outer sheath to form a pig tail.
- 2 Connect the earthing lead and screen wires to the system earth.

NOTE :

A connector/bushing mated combination should not be allowed to carry the full weight of the cable. Therefore it is necessary to clamp the cable as close as possible to the connector.

IMPORTANT NOTES :

- **Never disconnect the connector from energised equipment nor energise a disconnected connector without previously installing on its appropriate corresponding mating part.**
- **Do not allow hydrocarbon oils or solvents to contaminate the E.P.D.M. rubber.**
In the event of contamination, wipe the surface clean with a dry cloth.

Euromold
a Nexans company

Nexans Network Solutions NV - div. EUROMOLD

Zuid III - Industrielaan 12
B-9320 EREMBODEGEM-AALST – BELGIUM
Tel: +32 (0)53/85 02 11 – Telefax: +32 (0)53/83 10 13
sales.euromold@nexans.com



FOR INFORMATION ONLY Please always use the instructions supplied in the kit

