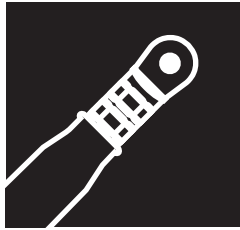


**CAUTION:**

Read instructions thoroughly and completely prior to beginning installation.

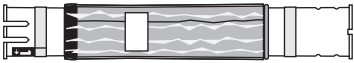
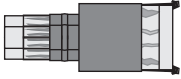

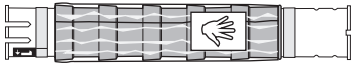











Installation instructions for cold-shrinkable outdoor termination



**T-OTK**  
124 & 224

For three core copper tape screened cable with extruded easy strip semi-conductive screens.

**Contents :**

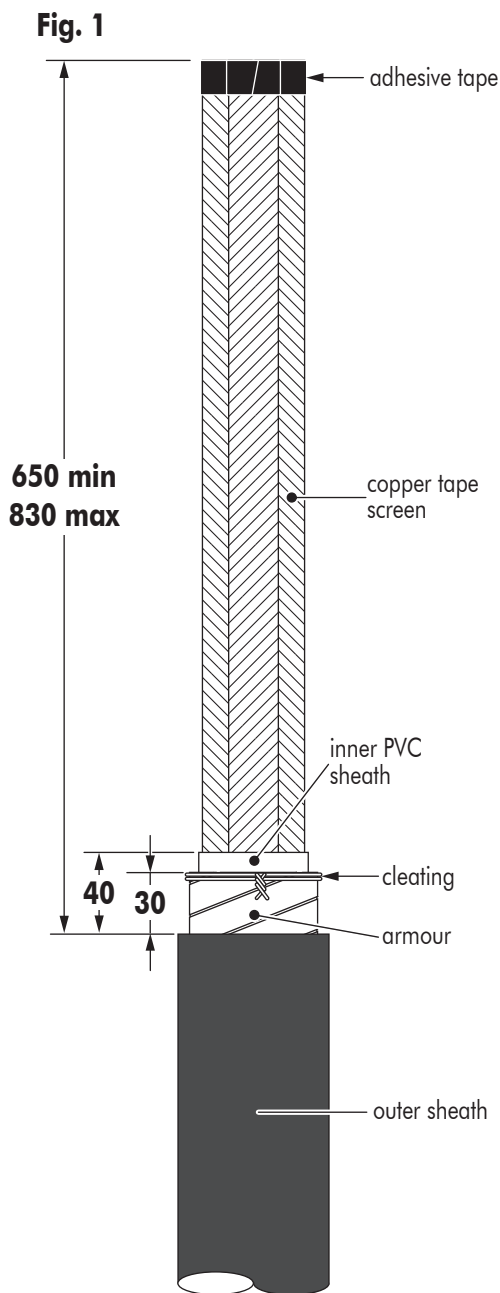
 <p>3 x Silicone tube</p>	 <p>1 x Cold-shrinkable breakout</p>	 <p>3 x Cold-shrinkable protective sleeve</p>		
 <p>3 x Silicone tube with sheds</p>	 <p>3 x Sealing mastic</p>	 <p>2 x Roll spring</p>	 <p>4 x Tinned copper cleating wire; 10/10 - L = 1 m</p>	
 <p>1 x Tinned copper earth braid; L = 800 mm</p>	 <p>1 x Tinned copper earth braid; L = 1200 mm</p>	 <p>1 x Pulling hook</p>	 <p>1 x Installation hook</p>	 <p>1 x adhesive tape</p>
 <p>Silicone grease + wipers</p>	 <p>Gloves</p>	 <p>Installation instructions</p>		



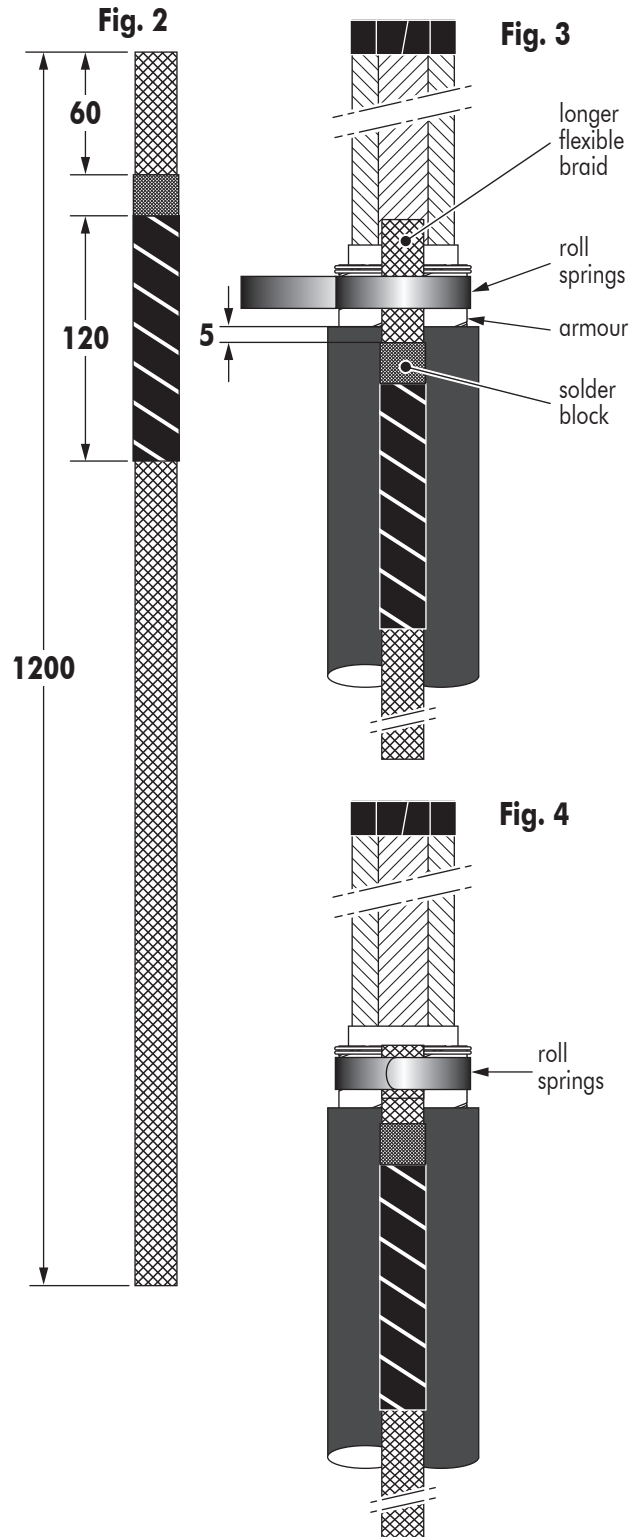
FOR INFORMATION ONLY Please always use the instructions supplied in the kit



## CABLE PREPARATION

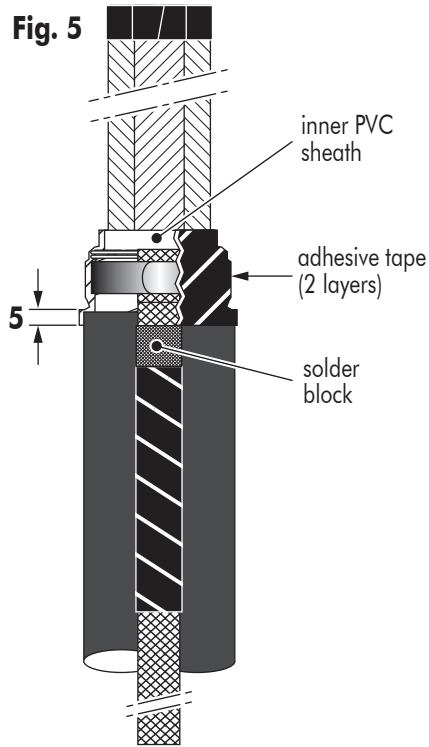


- 1** Remove :
  - the outer sheath for a minimum distance of **650 mm** and a maximum of **830 mm**. **The distance will be dictated by the overall dimensions of the equipment.**
  - the armour up to a point **30 mm** from the outer sheath and secure with tinned copper cleating wire.
  - the inner PVC sheath up to a point **40 mm** from the outer sheath.



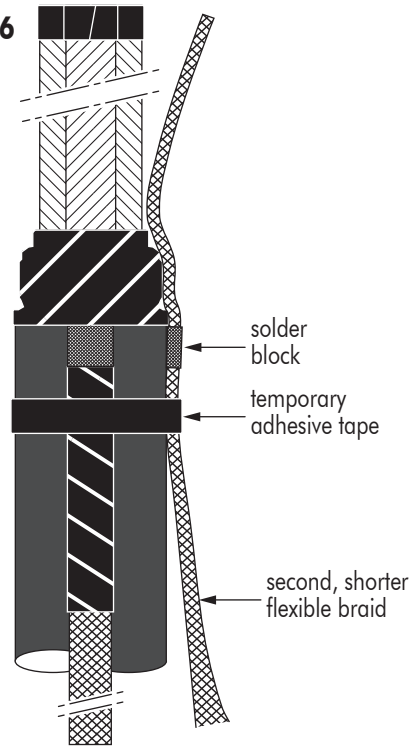
- 2** Starting below the solder block of the longer flexible braid, apply 2 layers of adhesive tape (50% overlap) for a length of **120 mm** (Fig. 2).
- 3** Position the longer flexible braid with its solder block **5 mm** below the cut back edge of the oversheath (as shown in Fig. 3).
- 4** Apply one turn of the roll spring around the armour. Bend down the longer braid over the roll spring and apply complete length of the roll spring (Fig. 4).

Fig. 5



- 5** Apply two layers of adhesive tape (50% overlap) starting on to the inner PVC sheath and ending **5** mm on to the oversheath (flush with the solder block on the braid).

Fig. 6



- 6** Position the second shorter flexible braid with its solder block **5** mm below the cut back edge of the outer sheath (as shown in Fig. 6). Make sure the two flexible braids do **NOT** touch each other.
- 7** Temporarily secure the second braid with adhesive tape.

Fig. 7a

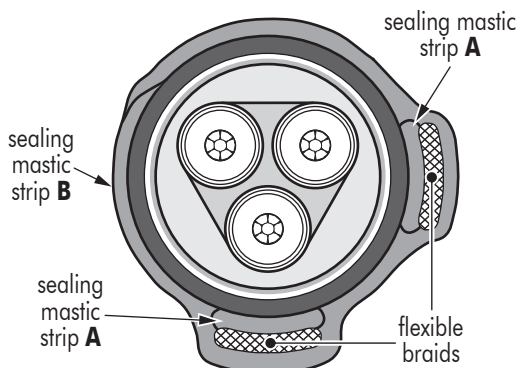
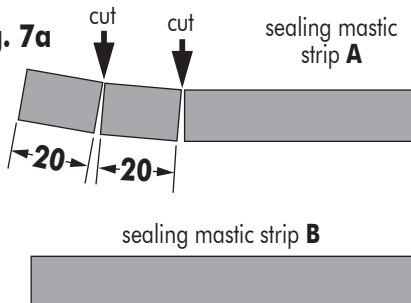


Fig. 7b

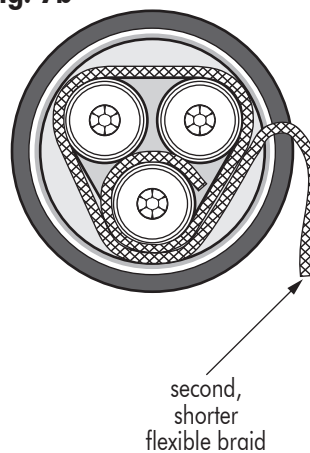
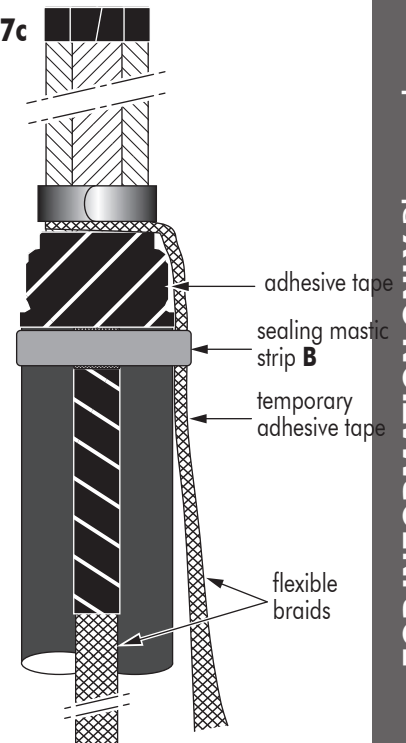


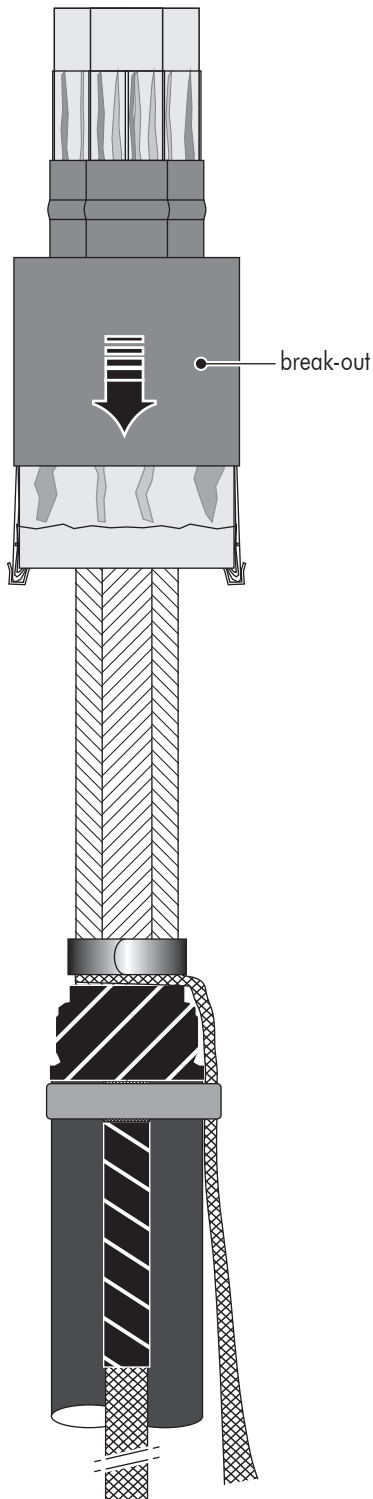
Fig. 7c



- 8** Cut off 2 pieces of approx. **20** mm of the sealing mastic strip **A** and apply them underneath the flexible braids, flush with the adhesive tape layer. The remaining length of the sealing mastic will be used in a later step (Fig. 7a).
- 9** Twist the second, shorter flexible braid one turn between and then around the copper tape screens as shown in Fig. 7b. Cut the remaining length of the second flexible braid.
- 10** Using the second roll spring cleat the second braid to the copper tape screens (Fig. 7c).
- 11** Apply the sealing mastic strip **B** around the cable and braids. Slightly stretch the mastic strip and completely encircle the cable (Fig. 7c). Remove the temporary adhesive tape.

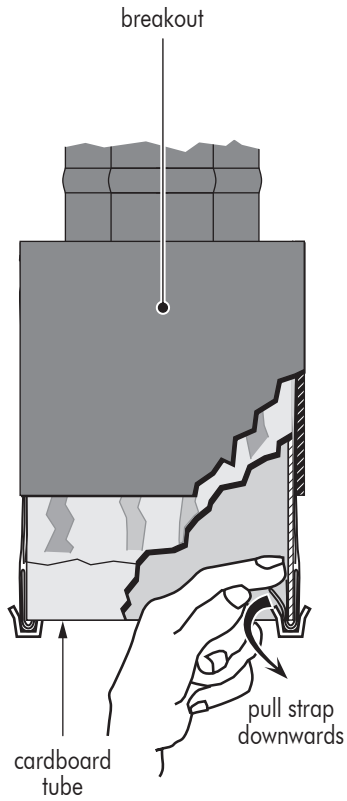
# INSTALLATION OF THE BREAK-OUT

**Fig. 8**

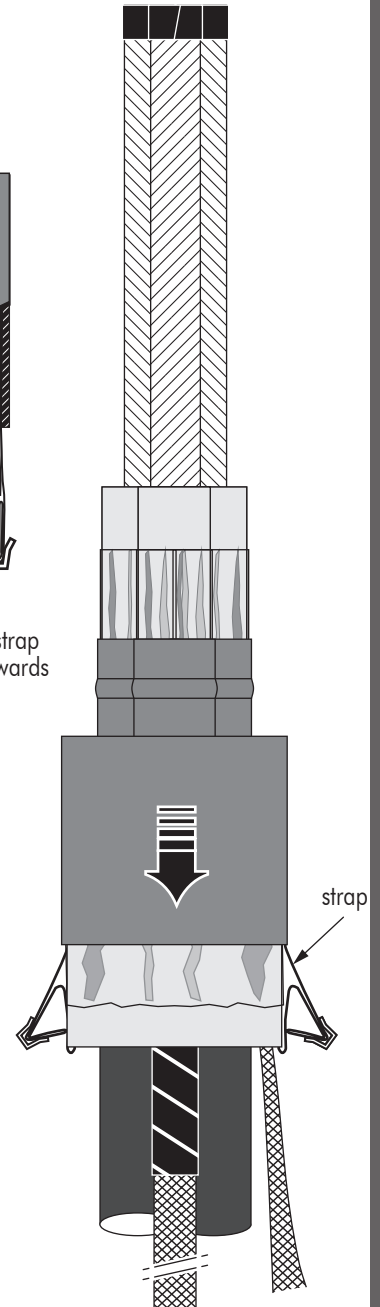


**1** Slide the breakout over the three cores and the outer sheath.

**Fig. 9a**



**Fig. 9b**



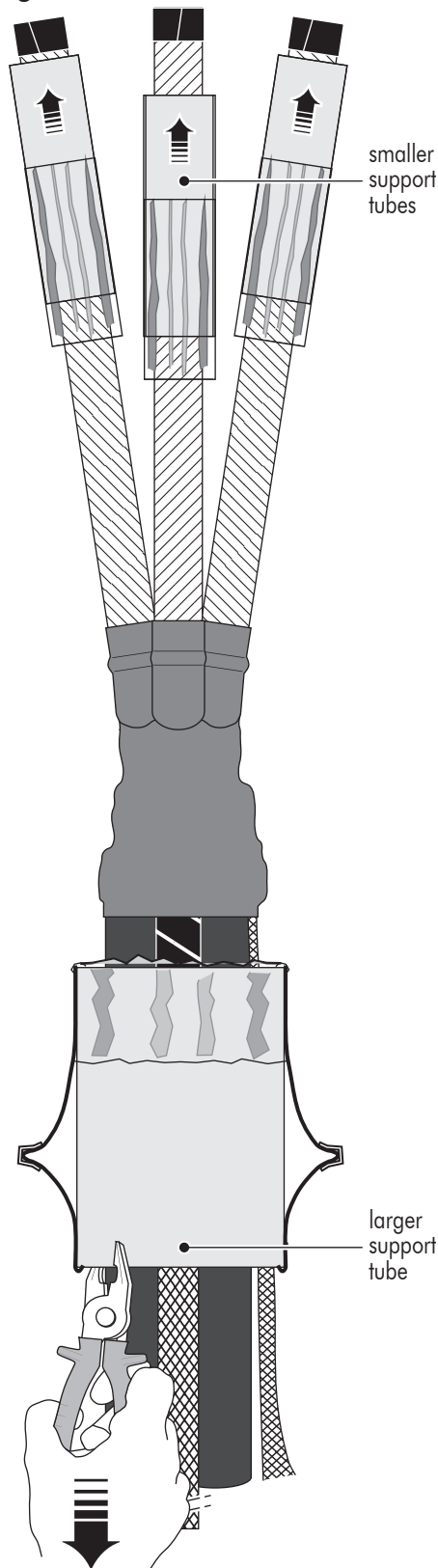
**2** Slightly spread the three cores to allow the breakout to be moved down as far as possible.  
**3** Unhook the straps from the inside of the cardboard tube by pulling downwards (Fig. 9a & 9b).



**FOR INFORMATION ONLY Please always use the instructions supplied in the kit**

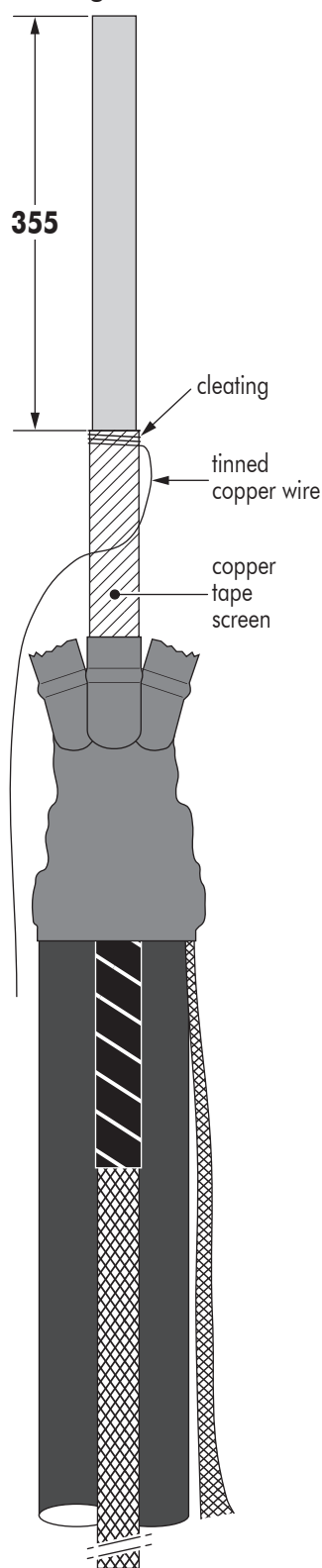


Fig. 10



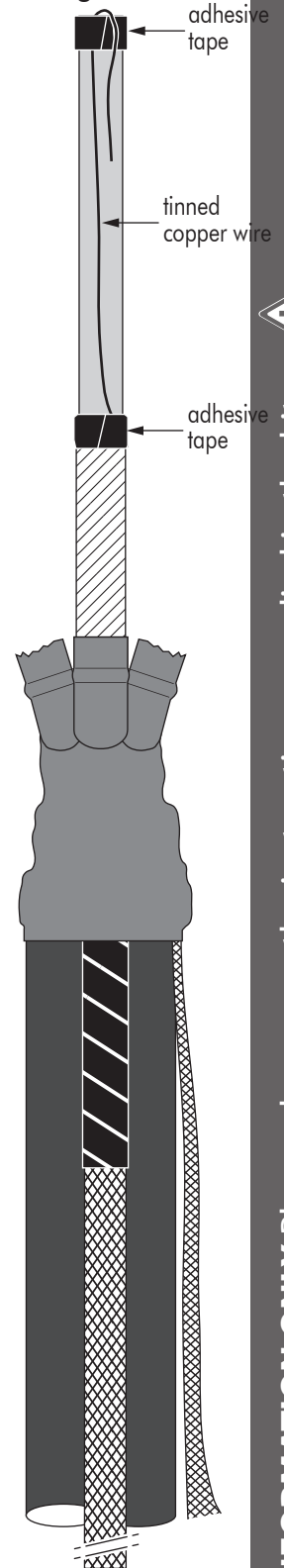
- 4 First pull out the larger support tube (use pliers to grab the cardboard tube).
- 5 Then pull out the smaller support tubes. Do not hold the plastic sliding film.
- 6 Remove the cardboard tubes from the cable.

Fig. 11



- 7 Using one end of the tinned copper wire, tightly cleat the copper tape screen at **355** mm from the cable end.
- 8 Remove the securing adhesive tape from the copper tape screen ends.
- 9 Remove the copper tape screen up to a point **355** mm from the cable end.

Fig. 12



- 10 Take the other end of the tinned copper wire, tightly cleat the copper wire to the cable end and secure with adhesive tape.
- 11 Wrap the cleating with adhesive tape.

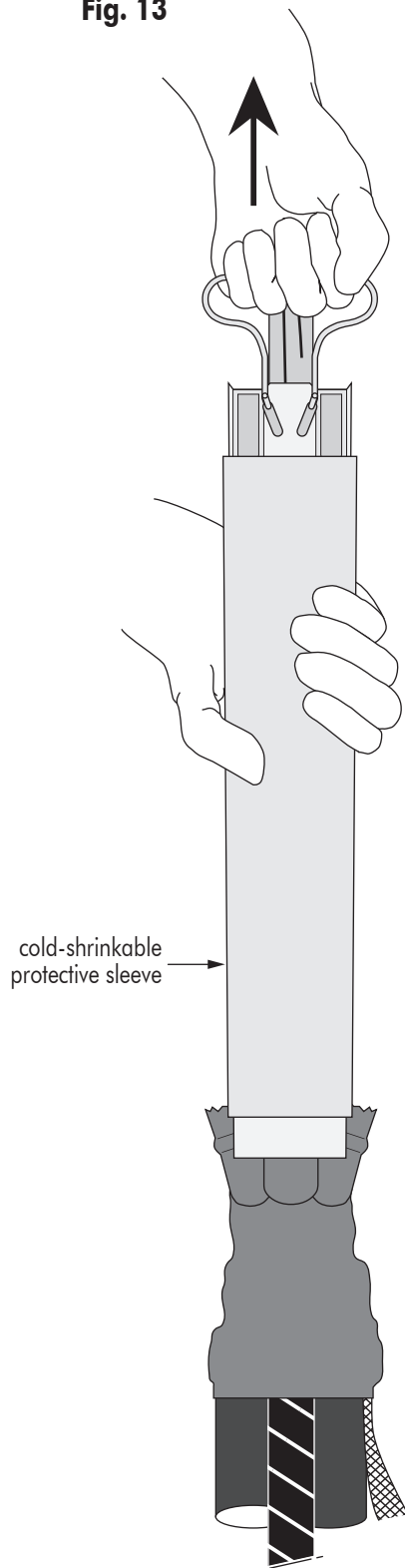


FOR INFORMATION ONLY Please always use the instructions supplied in the kit

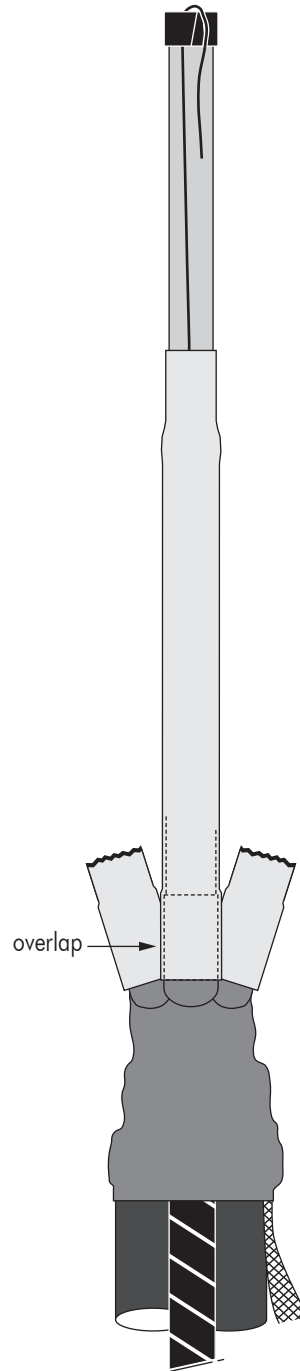


# INSTALLATION OF THE PROTECTIVE SLEEVES

**Fig. 13**



**Fig. 14**



- 1** Slide the cold-shrinkable protective sleeve over the cable core and breakout finger (Fig. 13).
- 2** Insert the pulling hook in the holes of the plastic tube.
- 3** Hold with one hand the protective sleeve while gently pulling out the plastic tube with the other hand.
- 4** Assure there is an overlap between the sleeve and the breakout finger (Fig. 14).

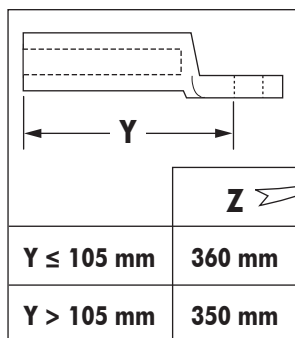


**FOR INFORMATION ONLY** Please always use the instructions supplied in the kit



## CABLE LUG CRIMPING

Fig. 15



$Y \leq 105 \text{ mm}$	360 mm
$Y > 105 \text{ mm}$	350 mm

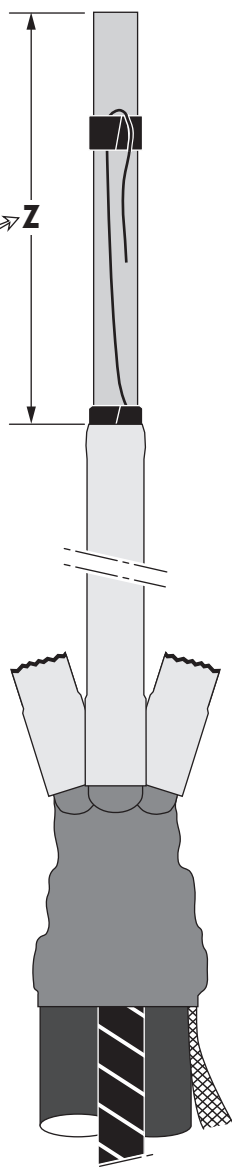


Fig. 16

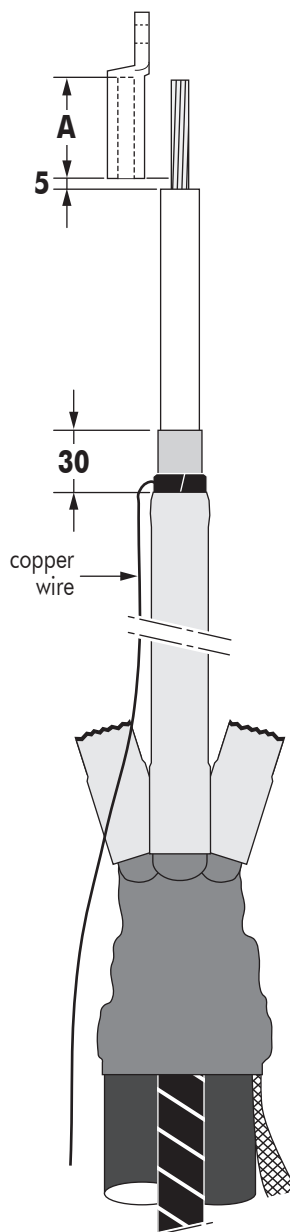
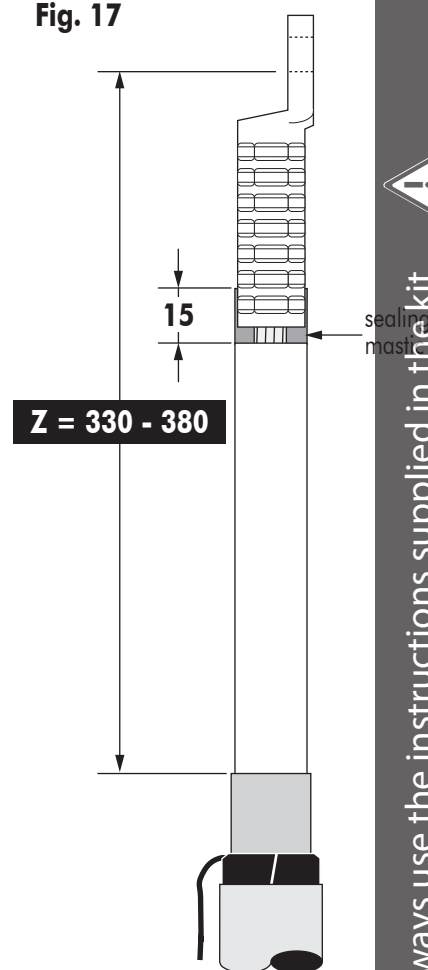


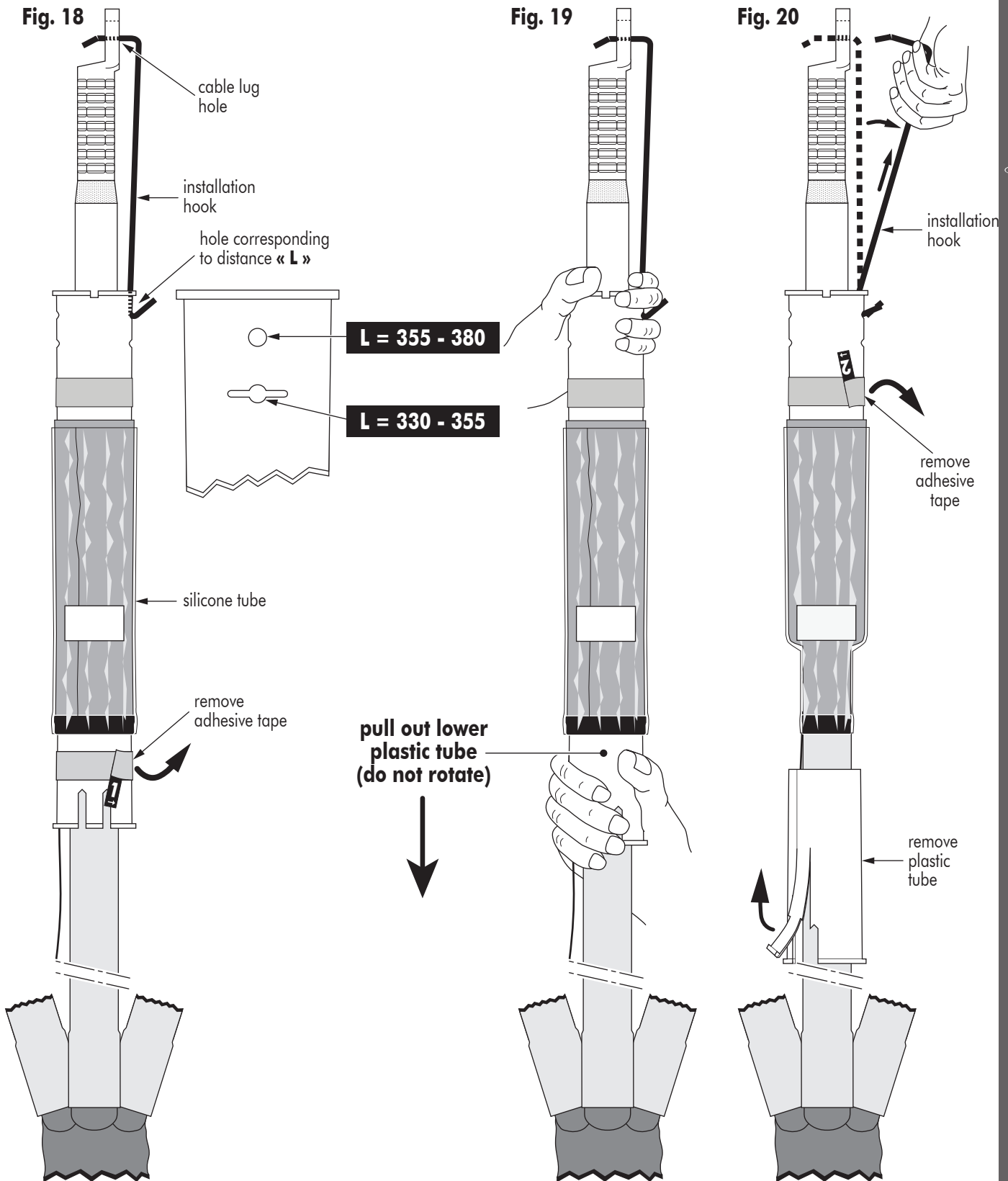
Fig. 17



- 1 Carefully cut the protective sleeve to distance, **Z** mm from the cable end (see table & Fig. 15).  
**Take care not to cut or nick the copper wire or underlying semi-conductive screen.**
- 2 Remove securing tape from the cable end and bend the copper wire downwards (Fig. 16).
- 3 Remove the semi-conductive screen up to a point **30** mm from the protective sleeve.
- 4 Remove the core insulation for a distance **A + 5** mm (**« A » = the bore depth of the compression lug**).

- 5 Install the cable lug and crimp. Remove any burrs after crimping. Clean cable lug and conductor.
- 6 As a check, measure distance **« L »** between the semi-conductive screen and cable lug hole. This distance should be between the dimensions specified.
- 7 Using the sealing mastic, fill up the gap between core insulation and cable lug and apply a **thin** layer around the cable lug up to a point **15** mm from the core insulation.

# INSTALLATION OF THE SILICONE TUBE



- 1** Slide the tube over the cable and insert the the installation hook in to the hole corresponding to distance « L » and through the cable lug hole (Fig. 18).
- 2** Remove adhesive tape from lower plastic tube (Fig. 18).
- 3** Hold the plastic tube (cable lug side) and installation hook with one hand and pull out the lower plastic tube without hesitation (Fig. 19).
- 4** Remove the installation hook and the lower plastic tube from the cable (Fig. 20).
- 5** Remove the adhesive tape from the top plastic tube (Fig. 20).



Fig. 21

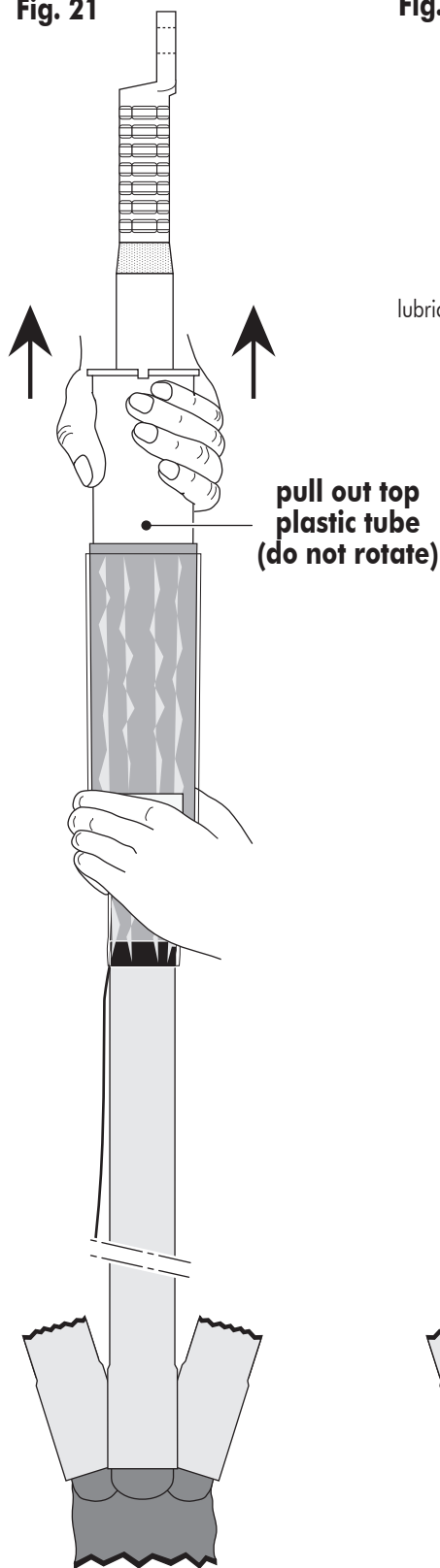
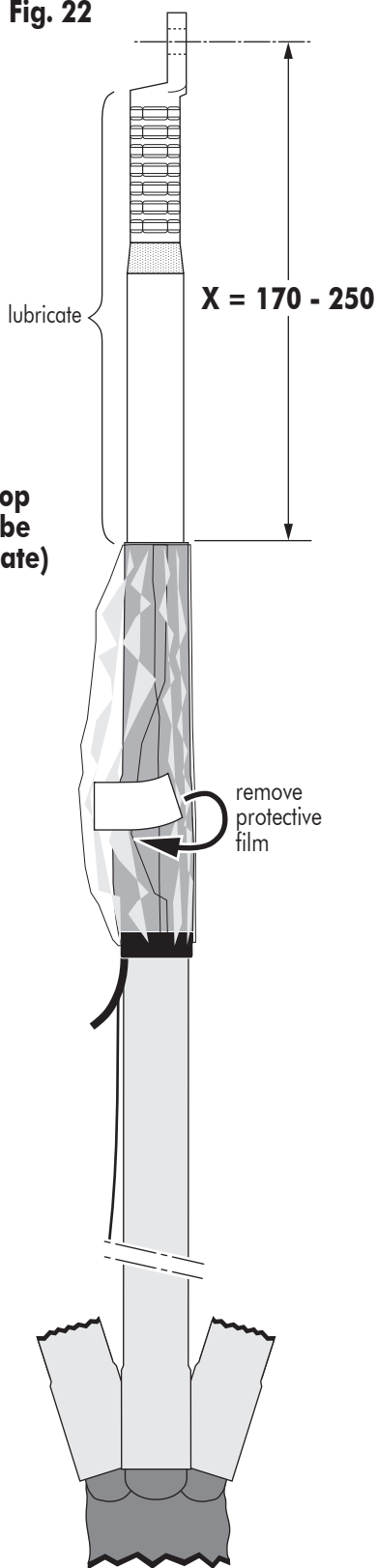
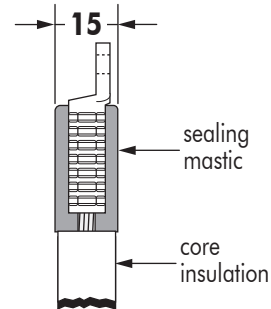


Fig. 22



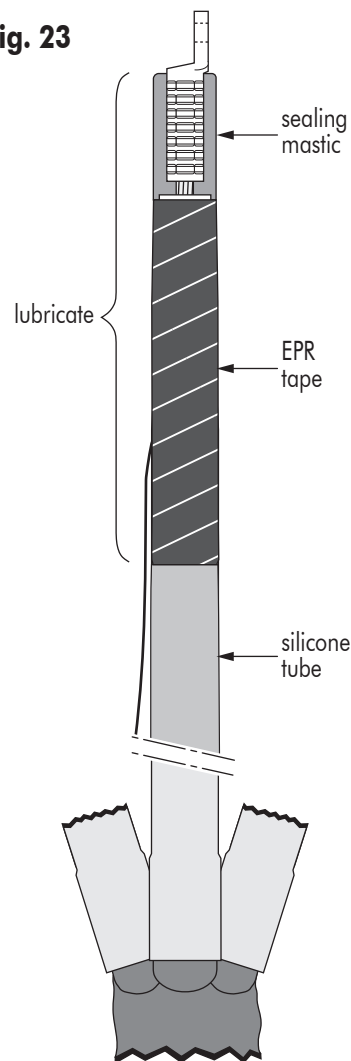
**For cable lug diameters less than 18 mm**



In case the cable lug diameter is less than 18 mm, build it up to a diameter of 19 mm using water sealing mastic.

**For core insulation diameters between 16 and 19 mm**

Fig. 23



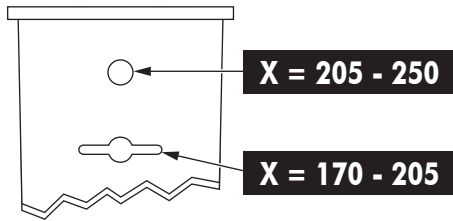
Apply EPR tape, starting from the top of the first silicone tube (50% overlapped) up to the water sealing mastic. Build up the tape until a diameter of 20 mm.

FOR INFORMATION ONLY Please always use the instructions supplied in the kit

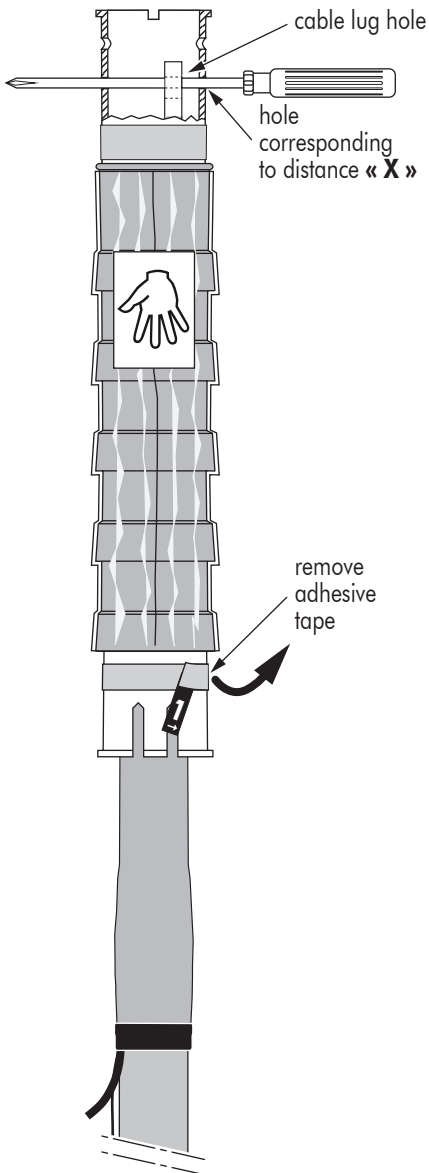


- 6 Hold the shrunk part of the silicone tube with one hand and pull out the top plastic tube without hesitation (Fig. 21).
- 7 Remove protective film (Fig. 22).
- 8 As a check, measure distance **X** between silicone tube and hole centre of the cable lug (Fig. 22).
- 9 Lubricate\* the core insulation and cable lug (**Do not lubricate the silicone tube**) (Fig. 23).

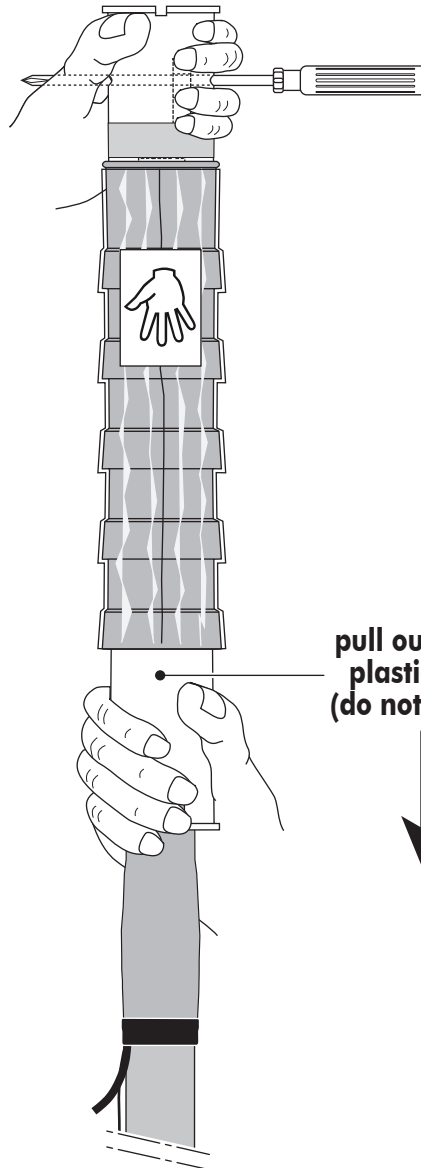
## INSTALLATION OF THE SILICONE TUBE WITH SHEDS



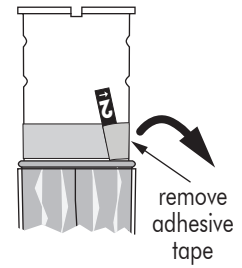
**Fig. 24**



**Fig. 25a**



**Fig. 25b**

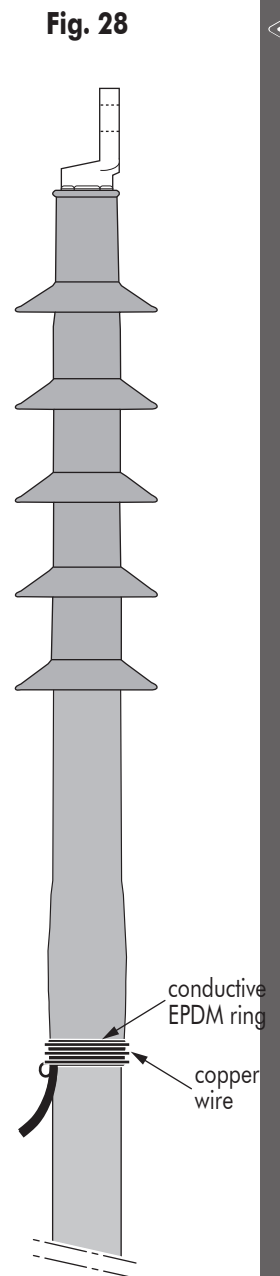
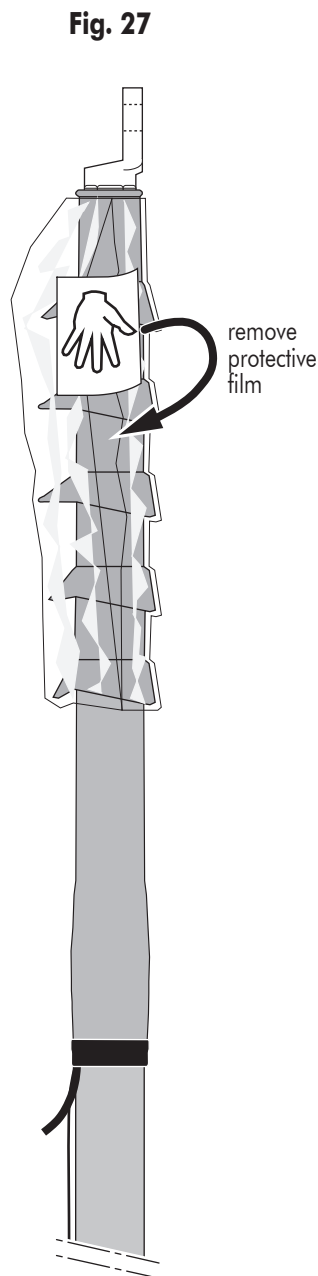
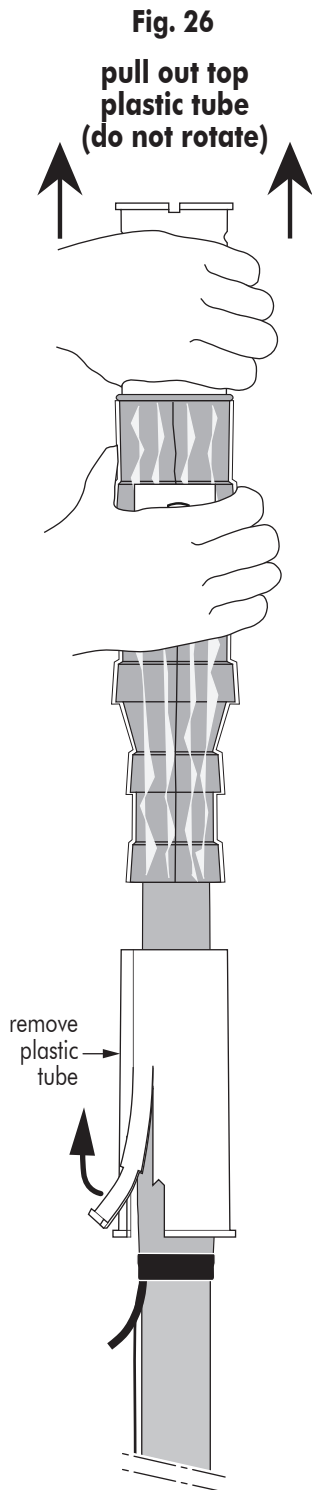


- 1 Slide the tube with sheds over the cable (Fig. 24).
- 2 Remove lower adhesive tape from lower plastic tube (Fig. 24).
- 3 Insert the screwdriver into the hole corresponding to distance «  $X$  » and through the cable lug hole (Fig. 24).
- 4 Hold the plastic tube (cable lug side) and screwdriver with one hand and pull out the lower plastic tube without hesitation (Fig. 25a).
- 5 Remove adhesive tape from the top plastic tube (Fig. 25b).



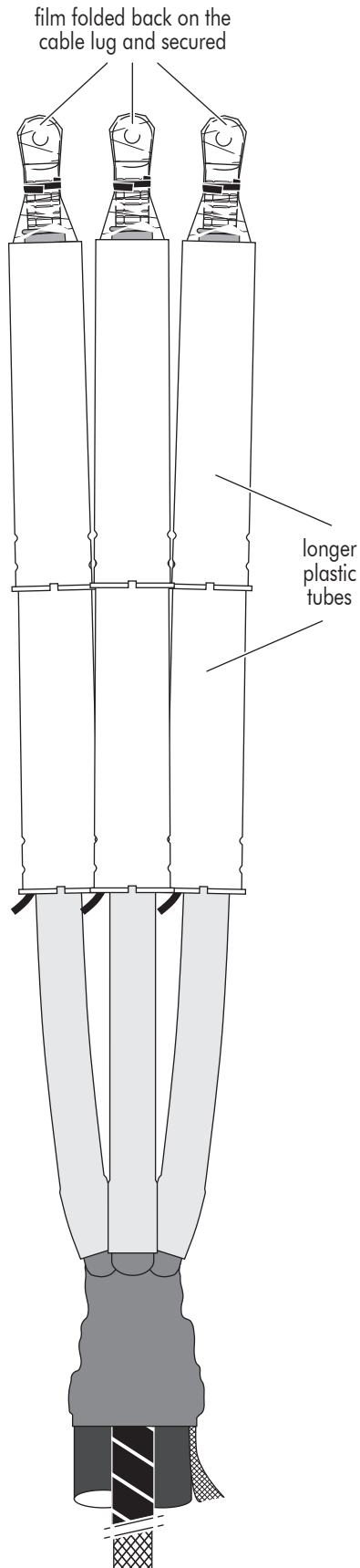
**FOR INFORMATION ONLY Please always use the instructions supplied in the kit**



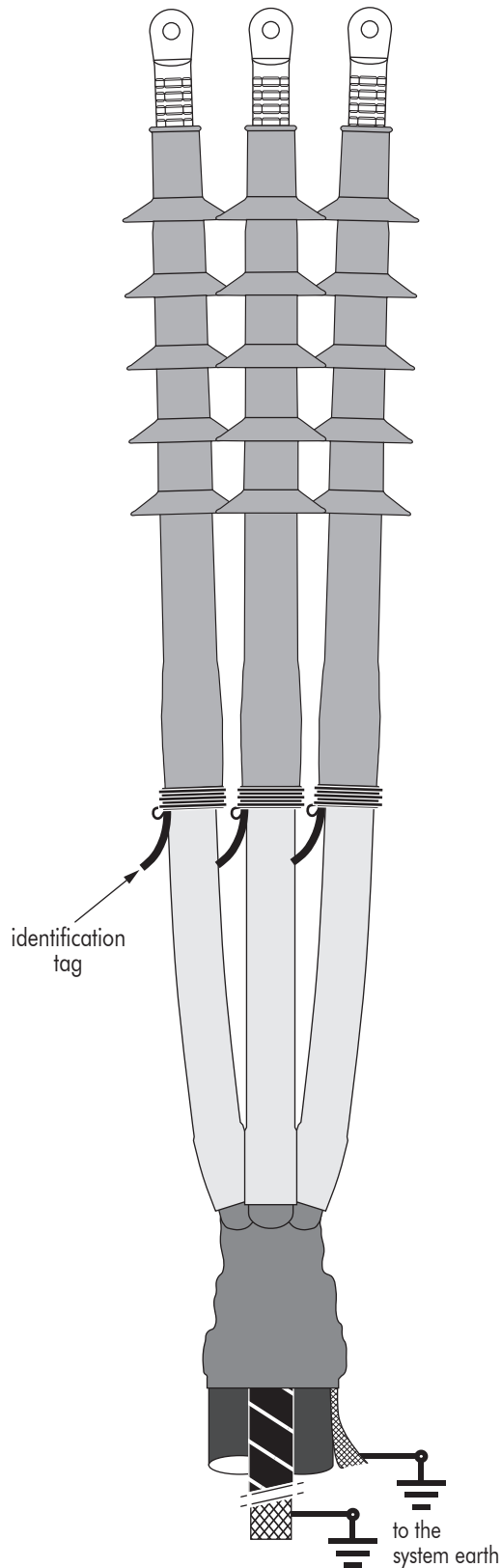


- 6** Remove lower plastic tube from the cable (Fig. 26).
- 7** Hold the non-shrunk part of the silicone tube with one hand and pull out the top plastic tube without hesitation (Fig. 26).
- 8** Remove protective film (Fig. 27).
- 9** Check that the silicone tube covers partially the crimp barrel and the lower silicone tube. Adjust if necessary.
- 10** Take the copper wire and twist it a few turns around the conductive EPDM ring (Fig. 28).

**Fig. 29**



**Fig. 30**



- 11** In order to protect the termination prior to its final connection, slide the longer plastic tubes over the termination as shown. Secure the top plastic tube with film with a wrap of vinyl tape (Fig. 29).
- 12** Before connecting the cable lugs, remove the plastic tubes and connect earth braid to the system earth (Fig. 30).



FOR INFORMATION ONLY Please always use the instructions supplied in the kit



**Euromold**  
a Nexans company

**Nexans Network Solutions NV - div. EUROMOLD**

Zuid III - Industrielaan 12  
B-9320 EREMBODEGEM-AALST - BELGIUM  
Tel: +32 (0)53/85 02 11 - Telefax: +32 (0)53/83 10 13  
sales.euromold@nexans.com